

MORGAN O'REILLY | PORTFOLIO

DGC TRAINEE ASSISTANT ART DIRECTOR (GAP) - SET DESIGN

E: morganoreilly.dgc@gmail.com

P: 416 888 3056

SPIRIT OF YORK BAR RETROFIT | ERA ARCHITECTS

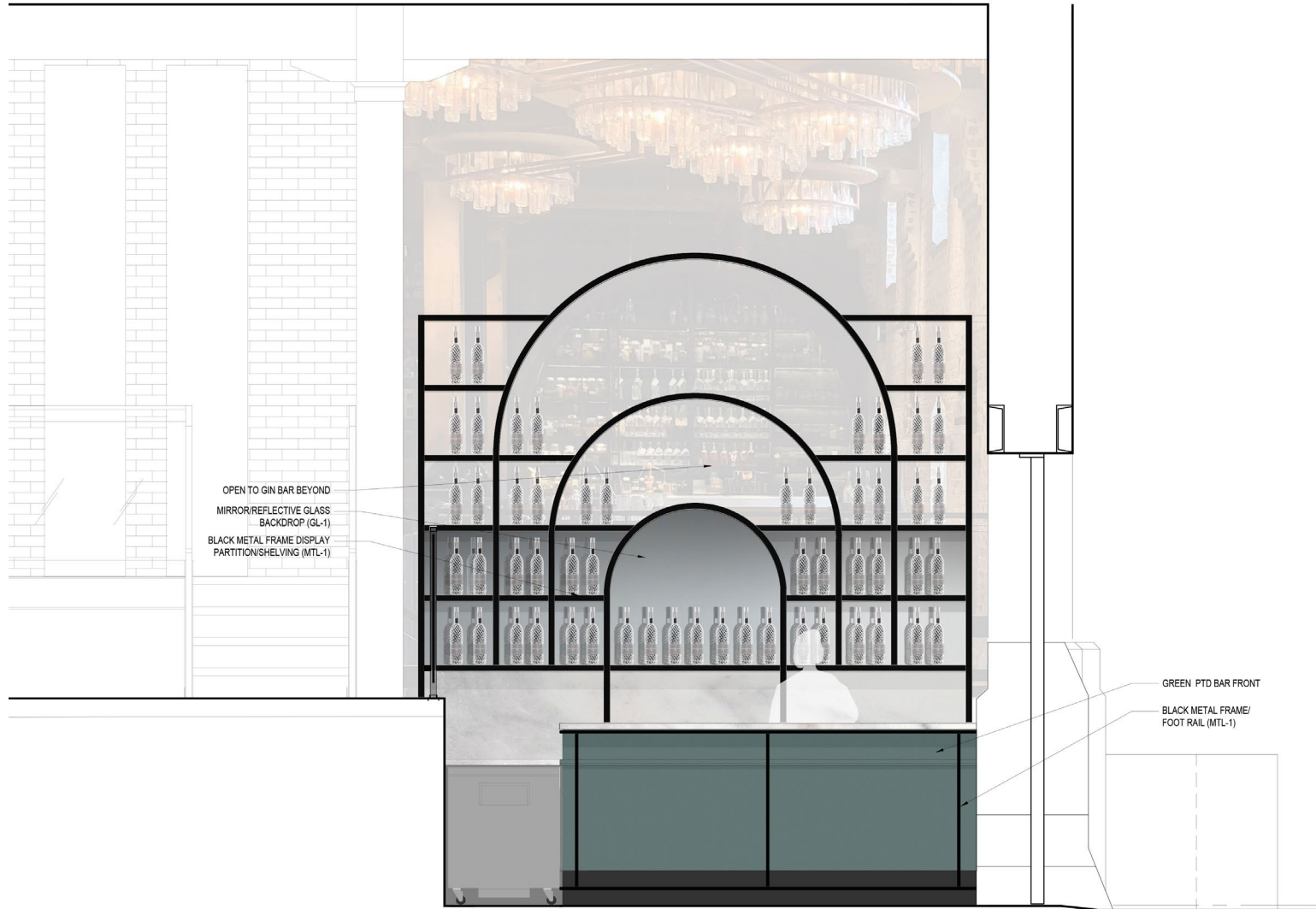

PROPOSED WET BAR ELEVATION (AUTOCAD & PHOTOSHOP)

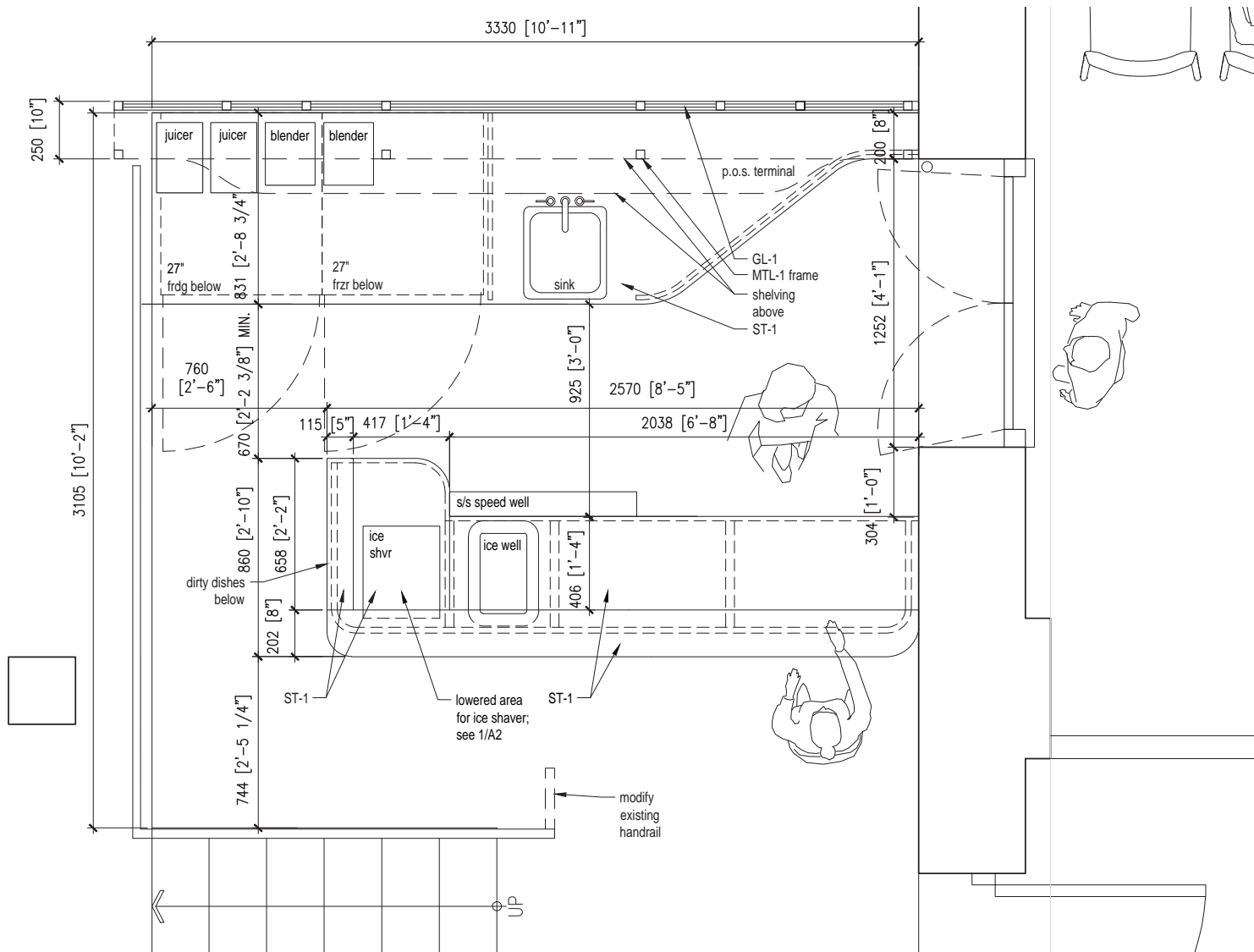

CONSTRUCTION DRAWINGS - WET BAR PLAN (AUTOCAD)

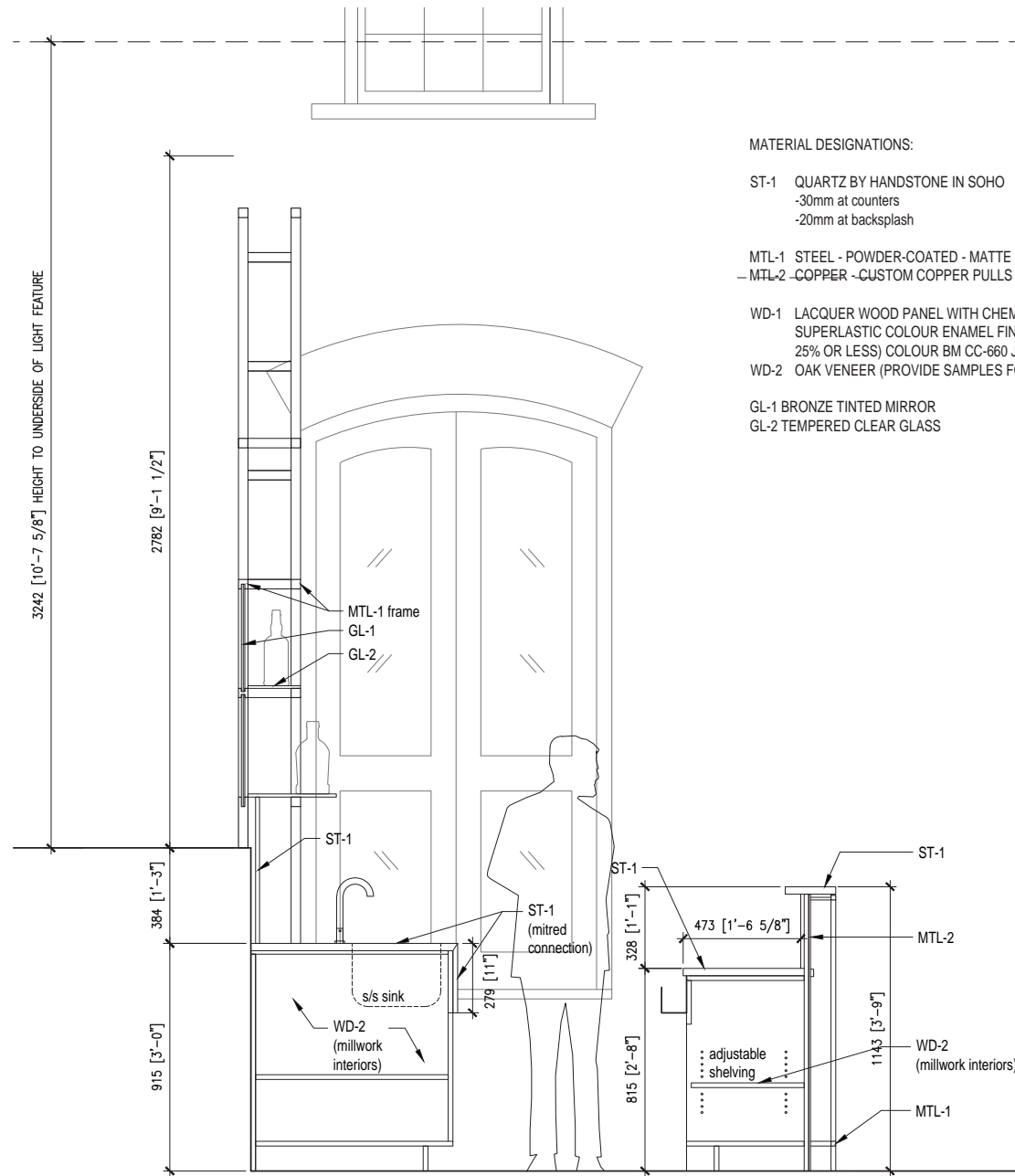

MATERIAL DESIGNATIONS:

ST-1 QUARTZ BY HANDSTONE IN SOHO
 -30mm at counters
 -20mm at backsplash

MTL-1 STEEL - POWDER-COATED - MATTE BLACK
 - MTL-2 -COPPER -CUSTOM COPPER PULLS

WD-1 LACQUER WOOD PANEL WITH CHEMCRAFT 441
 SUPERLASTIC COLOUR ENAMEL FINISH (MATTE
 25% OR LESS) COLOUR BM CC-660 JACK PINE)
 WD-2 OAK VENEER (PROVIDE SAMPLES FOR APPROVAL)

GL-1 BRONZE TINTED MIRROR
 GL-2 TEMPERED CLEAR GLASS

CONSTRUCTION DRAWINGS - WET BAR SECTION (AUTOCAD)

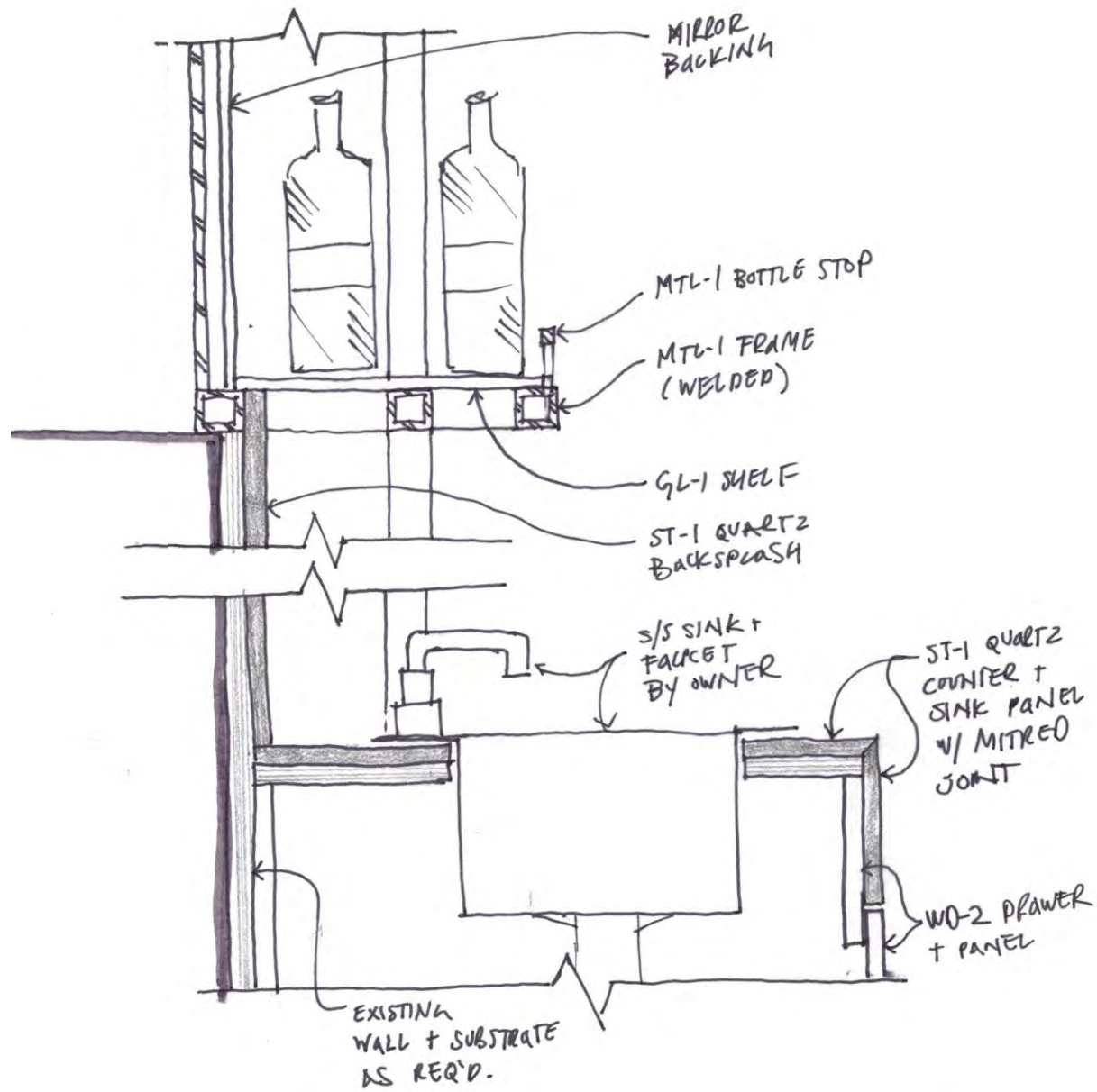

MILLWORK DETAIL SKETCH (BY HAND)

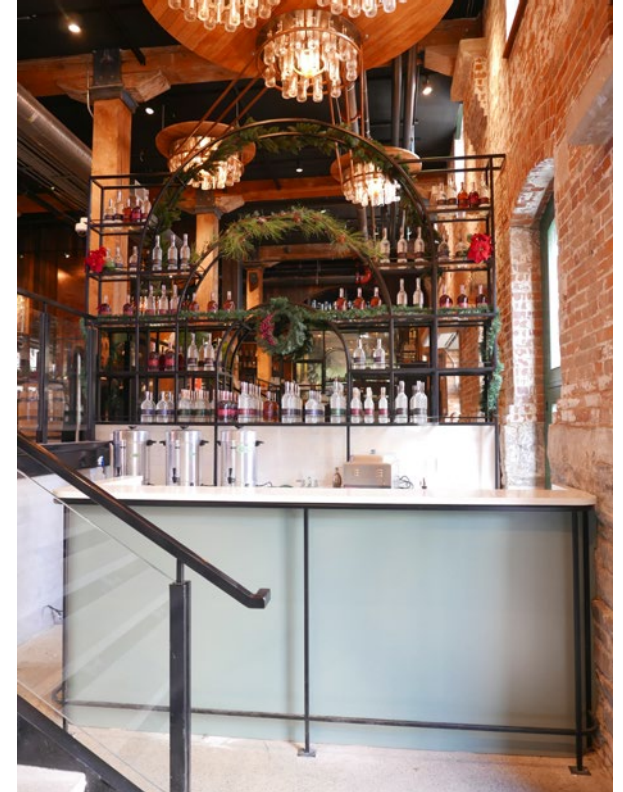

WET BAR BEFORE & AFTER PHOTOS

POINT AU BARIL COTTAGE | ERA ARCHITECTS

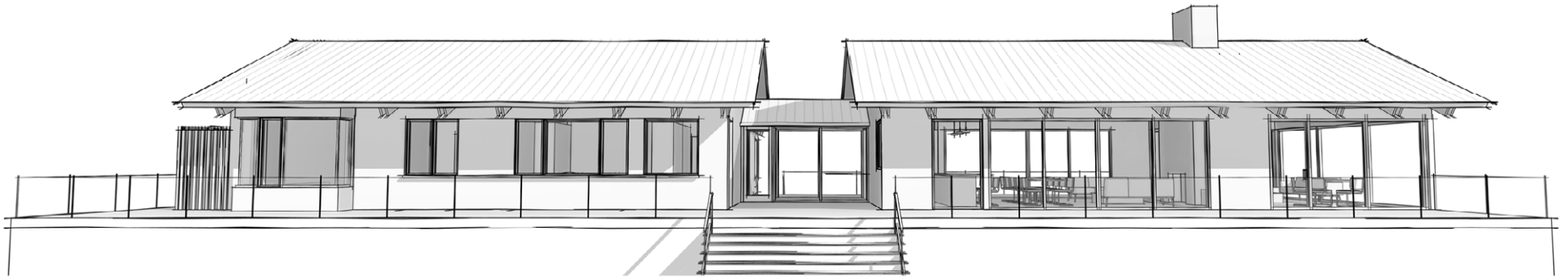

VIEW OF COTTAGE - LAKE-FACING (NORTH) ELEVATION (REVIT MODEL)

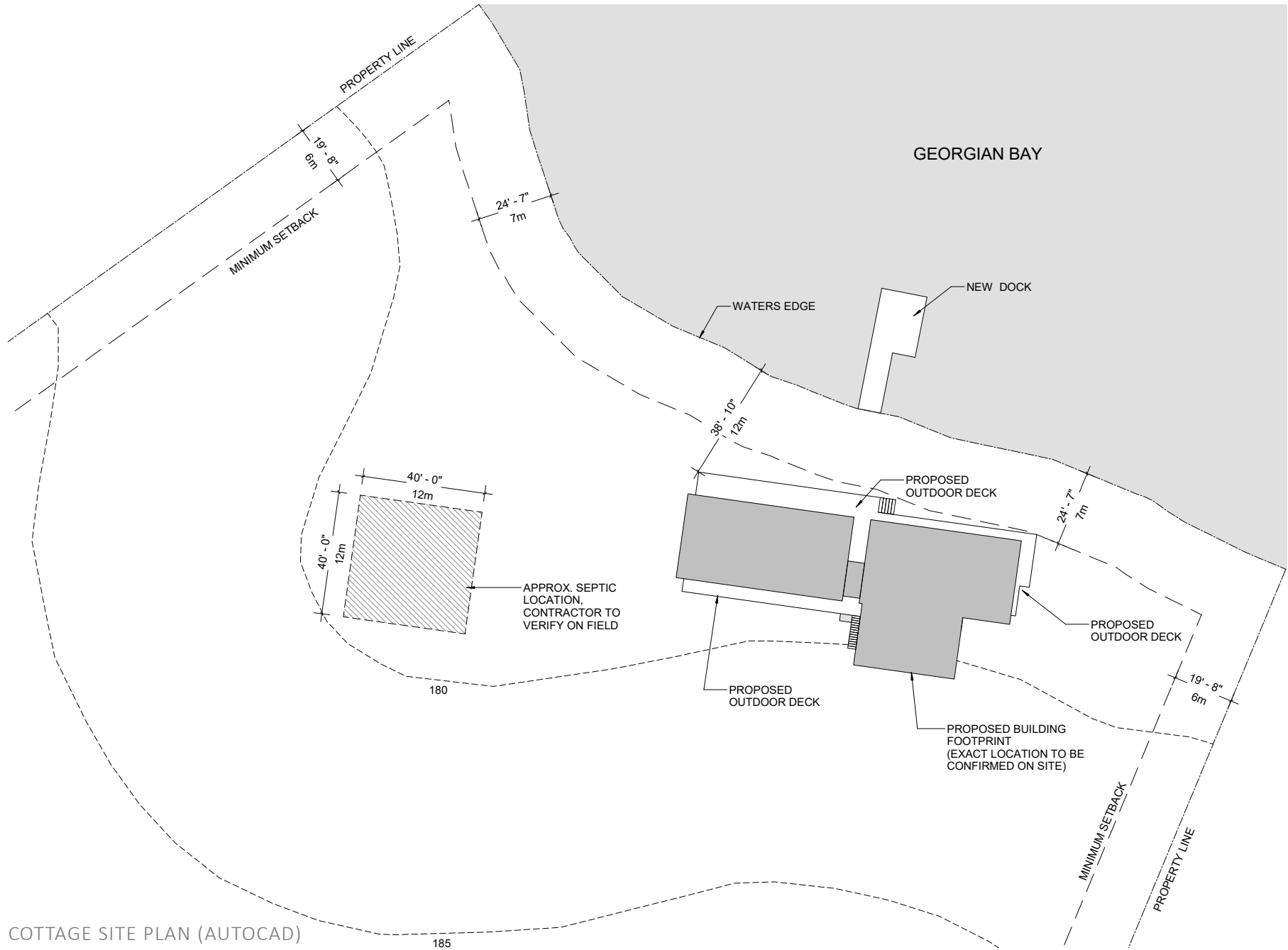

COTTAGE SITE PLAN (AUTOCAD)

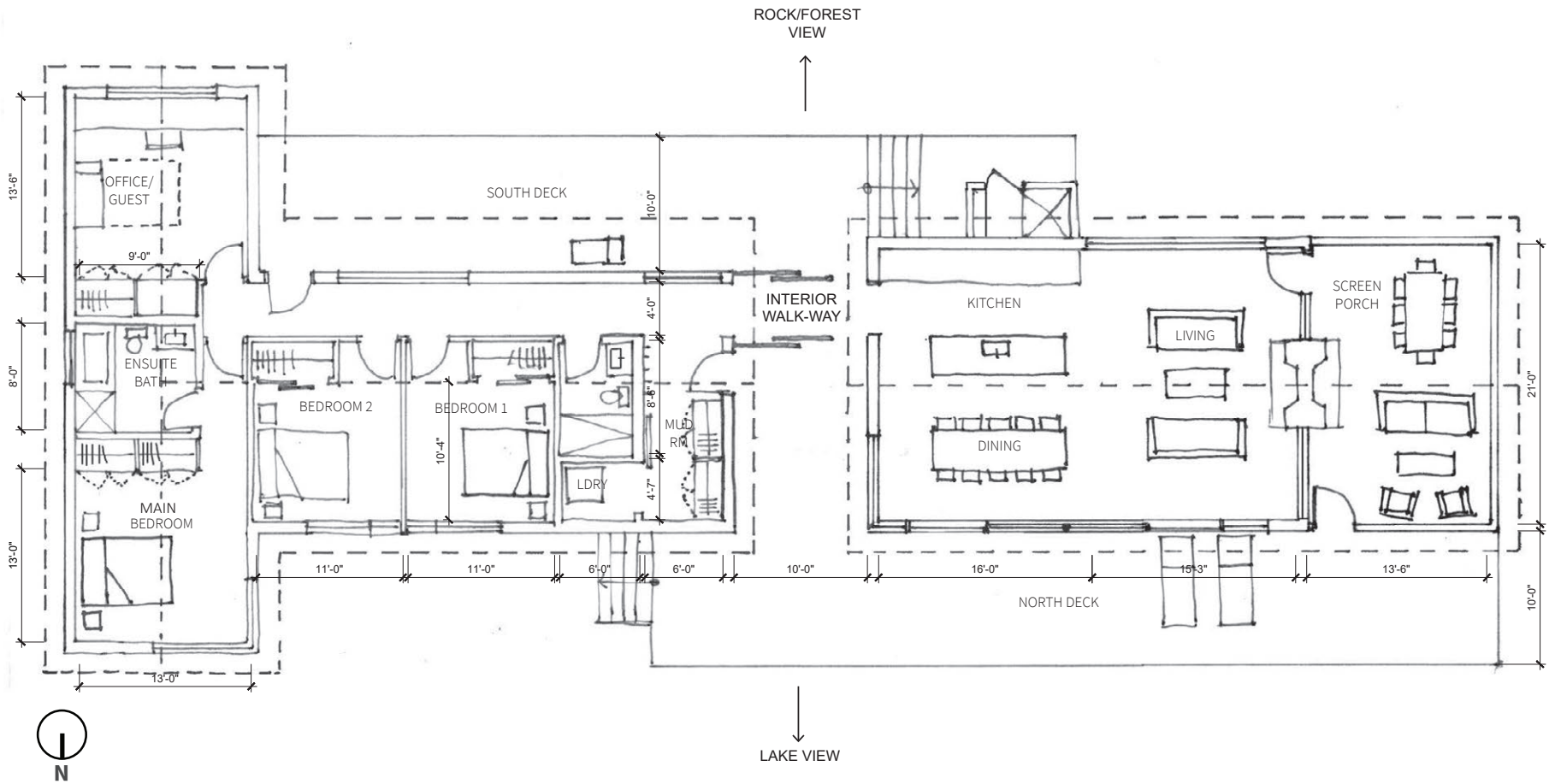

SCHEMATIC DESIGN OPTION 1A PLAN (HAND DRAWING)

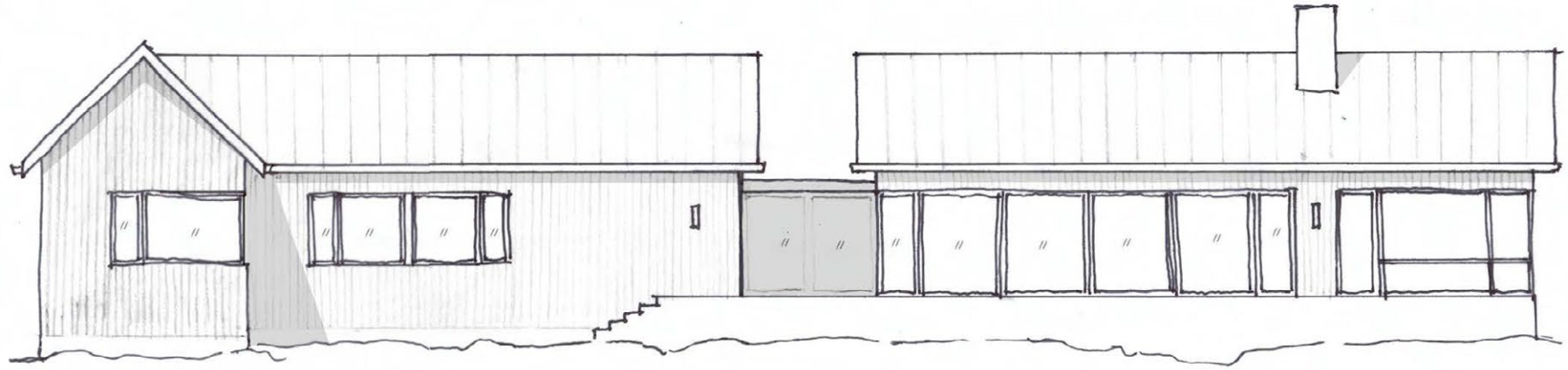

SCHEMATIC DESIGN OPTION 1A NORTH ELEVATION (FACING LAKE)



SAMPLE OF MOOD BOARD IMAGES GATHERED FOR OPTION 1A

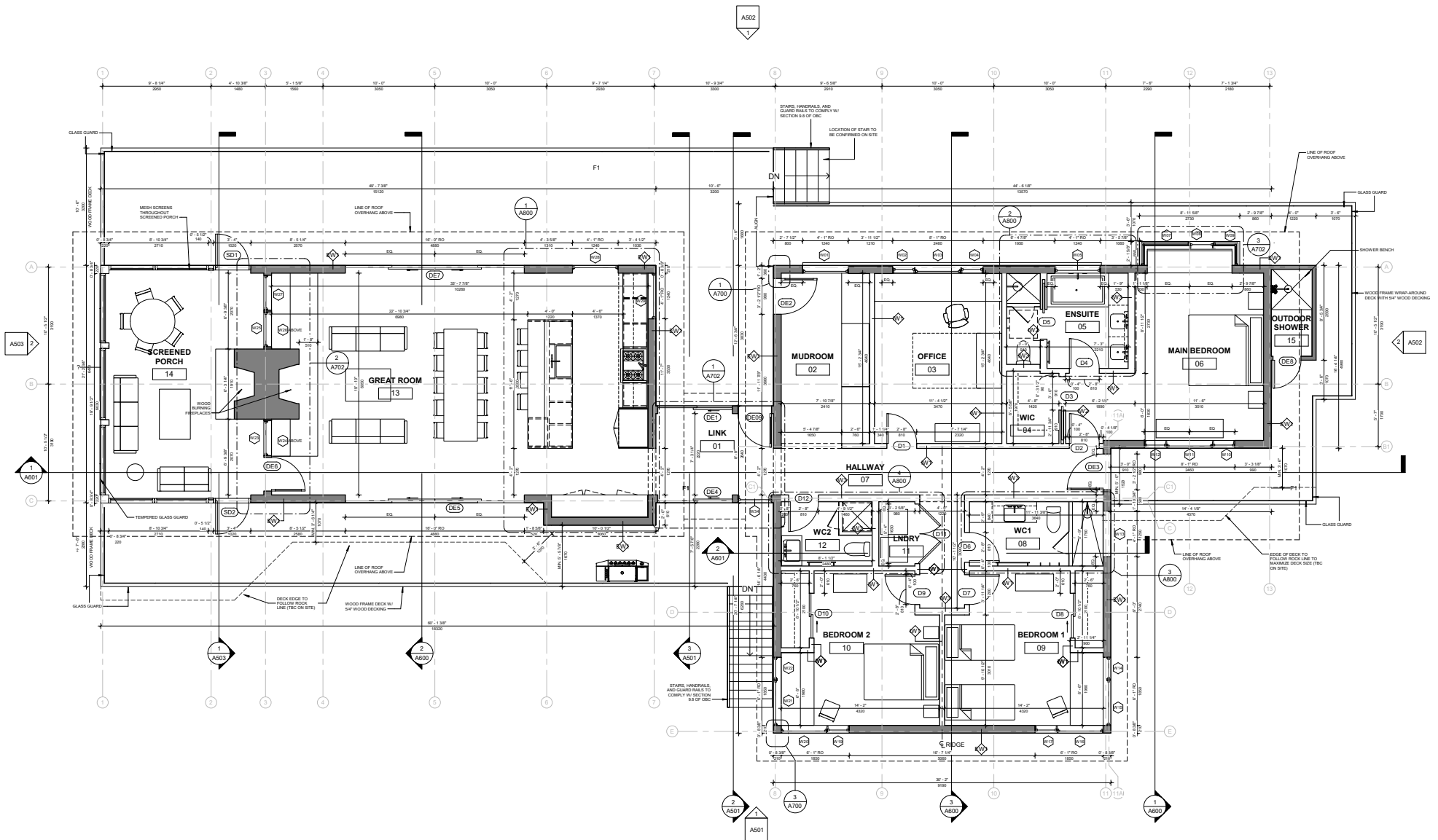

CONSTRUCTION DRAWINGS - COTTAGE PLAN (REVIT)



INTERIOR VIEW OF KITCHEN (SKETCHUP)

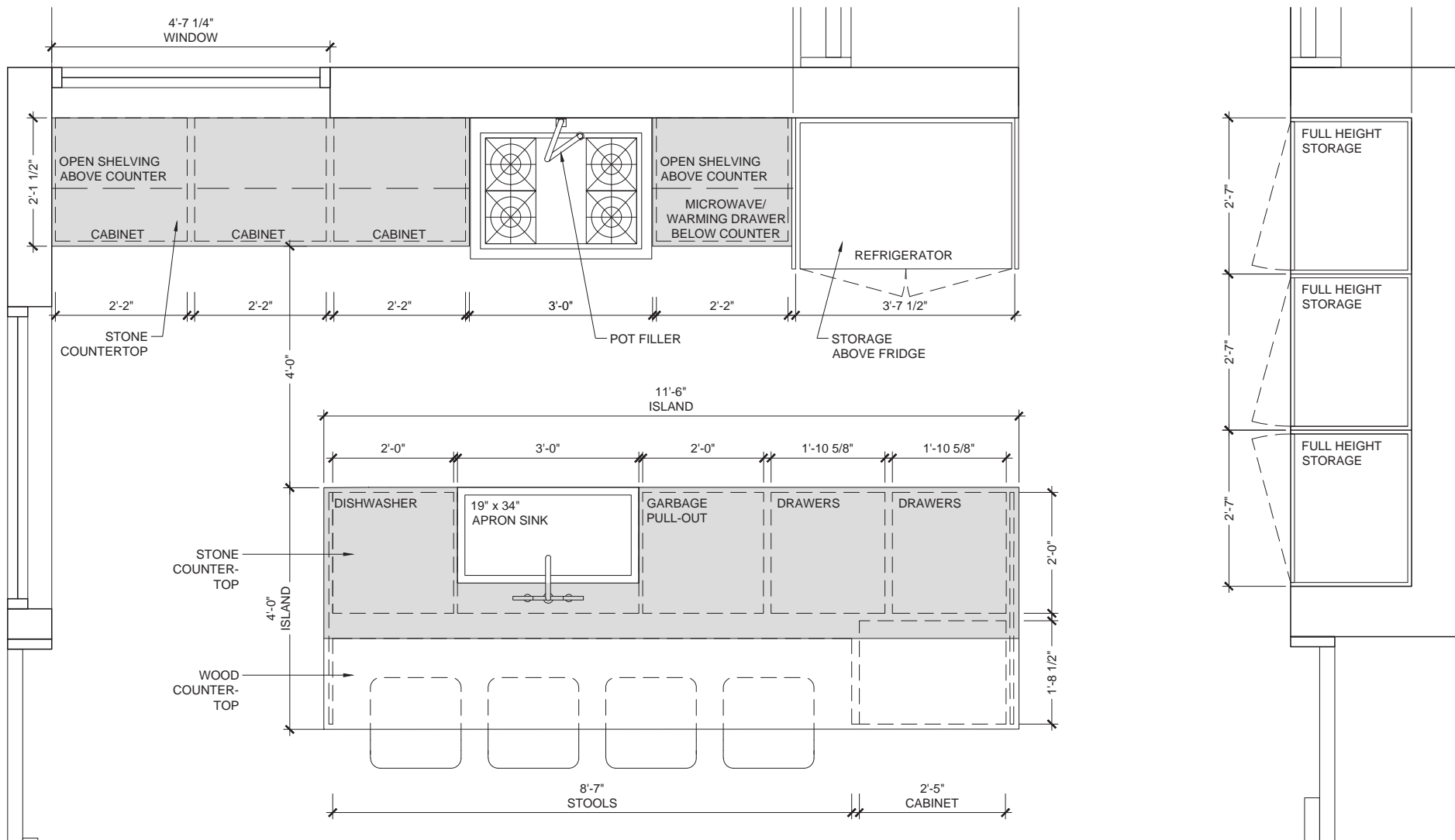

KITCHEN PLAN (AUTOCAD)



INTERIOR VIEW OF KITCHEN/DINING/CORRIDOR (SKETCHUP)



INTERIOR VIEW OF KITCHEN/DINING (SKETCHUP)



INTERIOR VIEW OF GREAT ROOM (SKETCHUP)

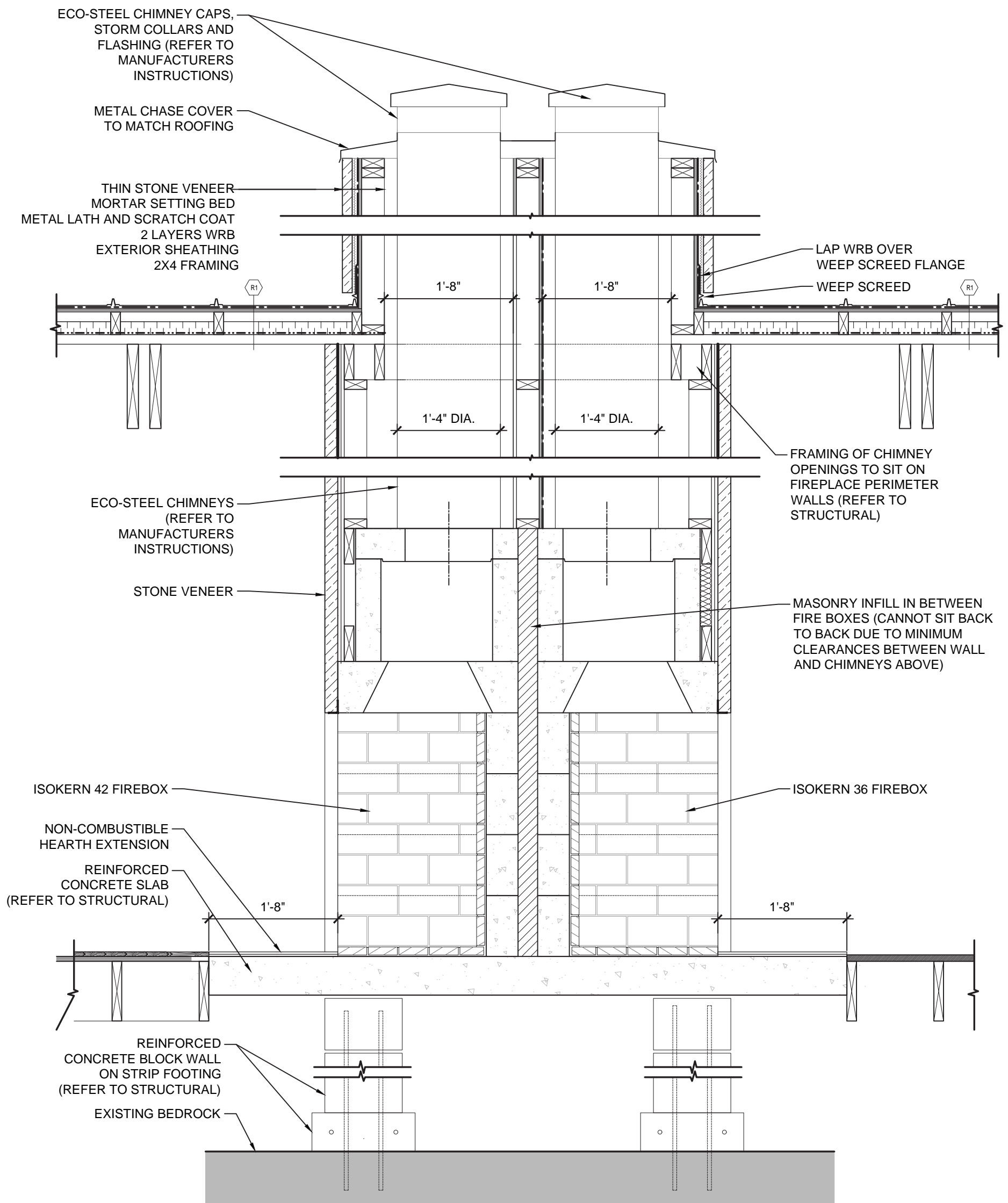

Section Detail at Fireplace 1
 SCALE 3/4" = 1'-0" A703

CONSTRUCTION DRAWINGS - DOUBLE FIREPLACE SECTION DETAIL

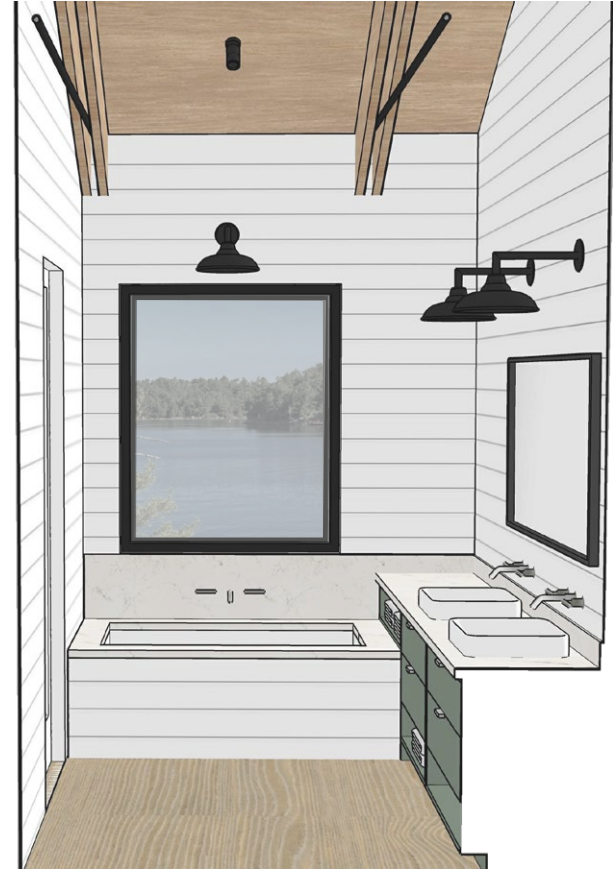

INTERIOR VIEWS OF PRIMARY BATHROOM (SKETCHUP)

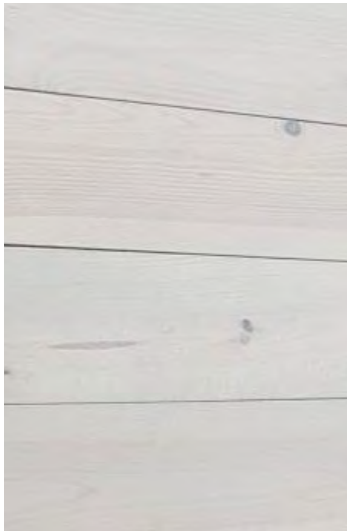

**PAINTED OR WHITE WASHED
HORIZONTAL WALL BOARD**
COLOUR: [BM WHITE DOVE](#)
WIDTH: 5 1/2"



SHOWER TILE
[PORCELAIN GENTLE STONE](#)
FROM STONE TILE
FINISH: WHITE
SIZE: COMBINATION OF LARGE
FORMAT (24"X48") AND MATCH-
ING MOSAIC ON FLOORS

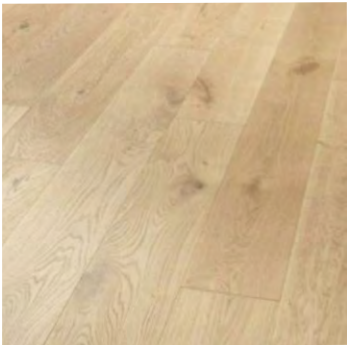

**WOOD FLOORING AND WOOD
CEILING (REFER TO BASE FIN-
ISHES)**

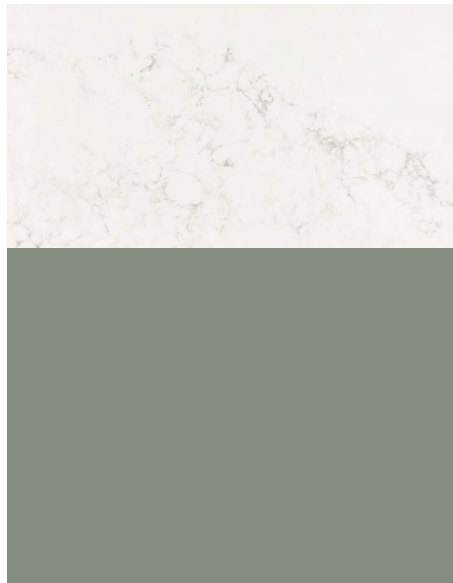

VANITY
COUNTER: HANSTONE (QUARTZ)
COLOUR: [YORKVILLE](#)

BASE: PAINTED (COLOUR: [BM CAROLINA GULL](#))



HARDWARE
SIMPLE CHROME DRAWER PULLS
(SPECS TO BE CONFIRMED WITH
MILLWORKER)

BATHROOM MATERIALITY

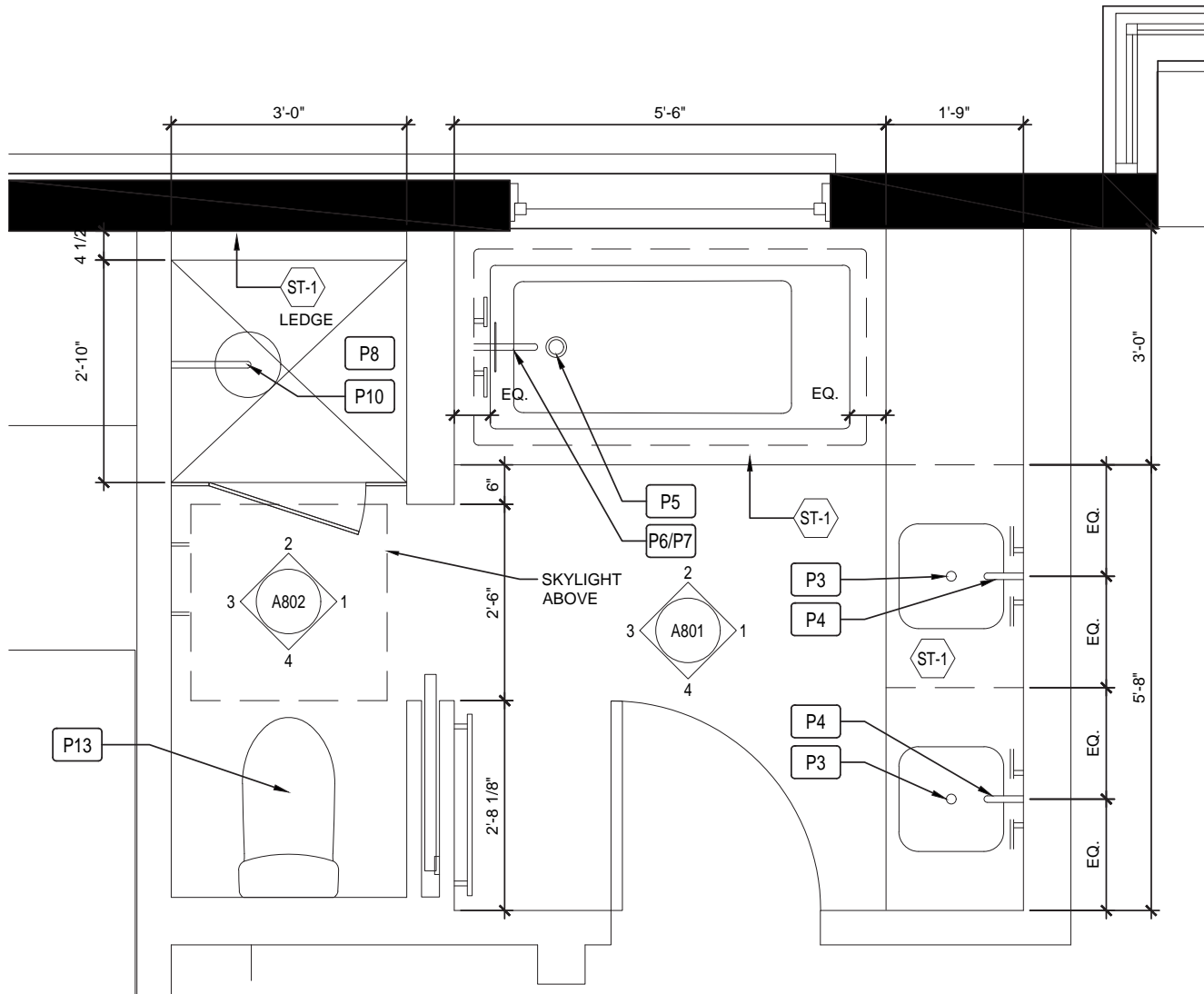

CONSTRUCTION DRAWINGS - PRIMARY BATHROOM PLAN (AUTOCAD)

Main Bath Plan

1

SCALE 1/2" = 1'-0"

A801

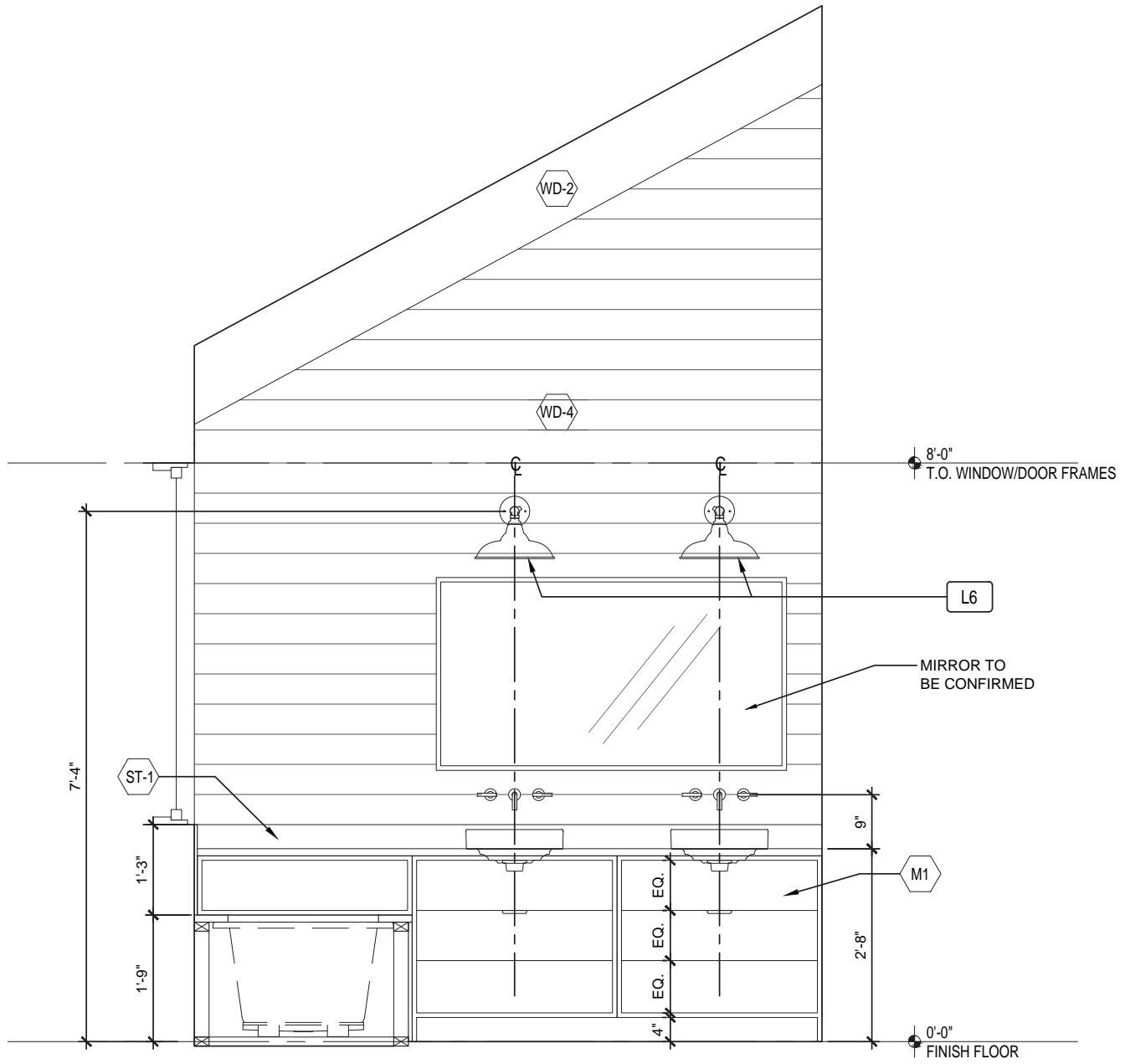

CONSTRUCTION DRAWINGS- PRIMARY BATH INTERIOR ELEVATION (AUTOCAD)

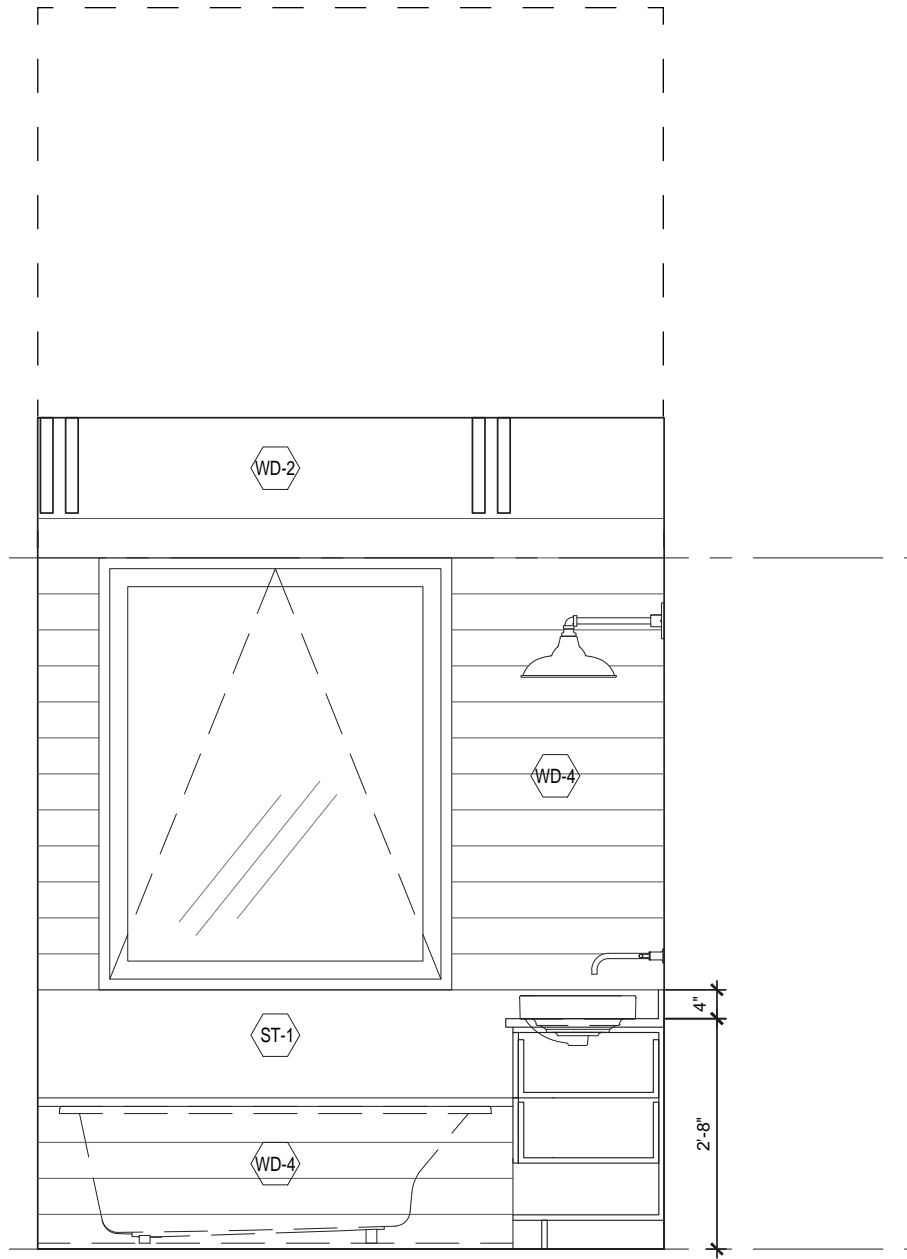

CONSTRUCTION DRAWINGS- PRIMARY BATH INTERIOR ELEVATION (AUTOCAD)

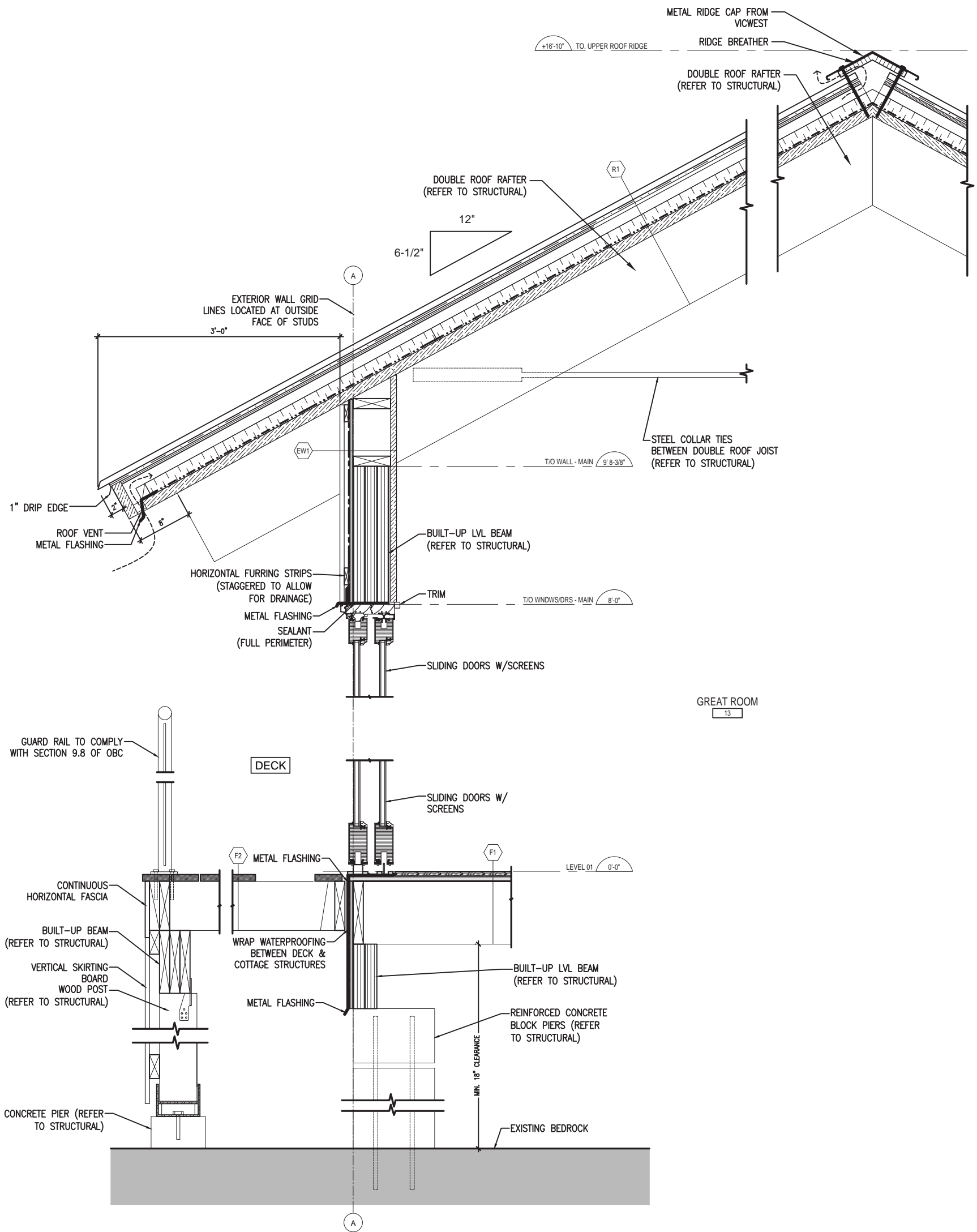

Typical Wall Section - Great Room

4

SCALE 3/4" = 1'-0"

A700

CONSTRUCTION DRAWINGS - TYPICAL CONSTRUCTION DETAIL



SITE PHOTO TAKEN JUNE, 2022



SITE PHOTO TAKEN JUNE, 2022



SITE PHOTO TAKEN OCTOBER, 2022



SITE PHOTO TAKEN OCTOBER, 2022



FINISHED PHOTO - CORRIDOR & RECEPTION ENTRANCE



VIEW OF CORRIDOR BENCH & ENTRANCE GLAZING (SKETCHUP)

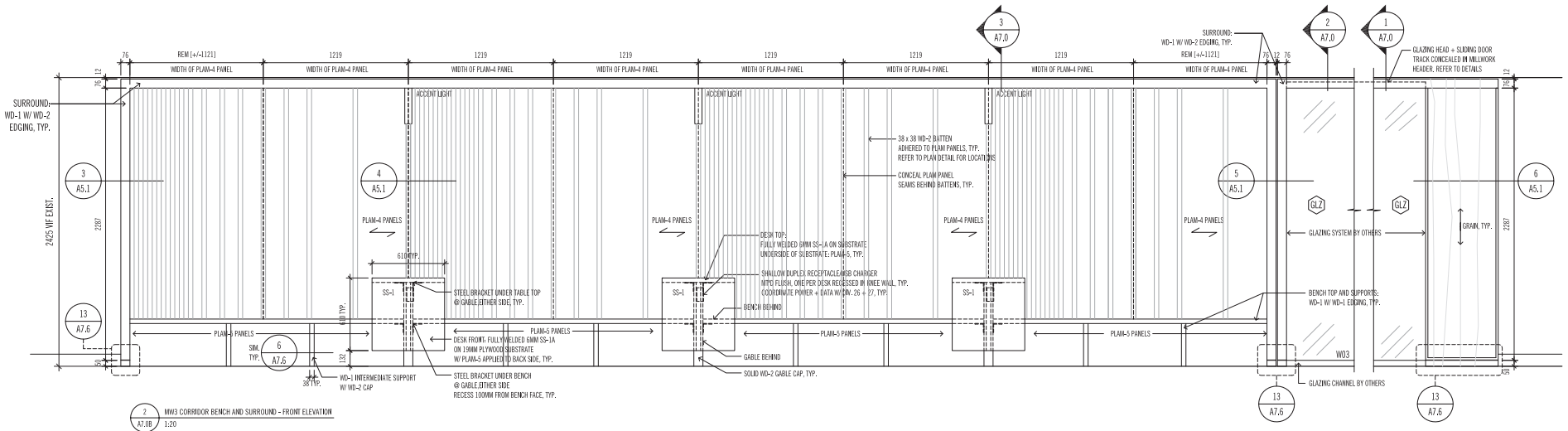
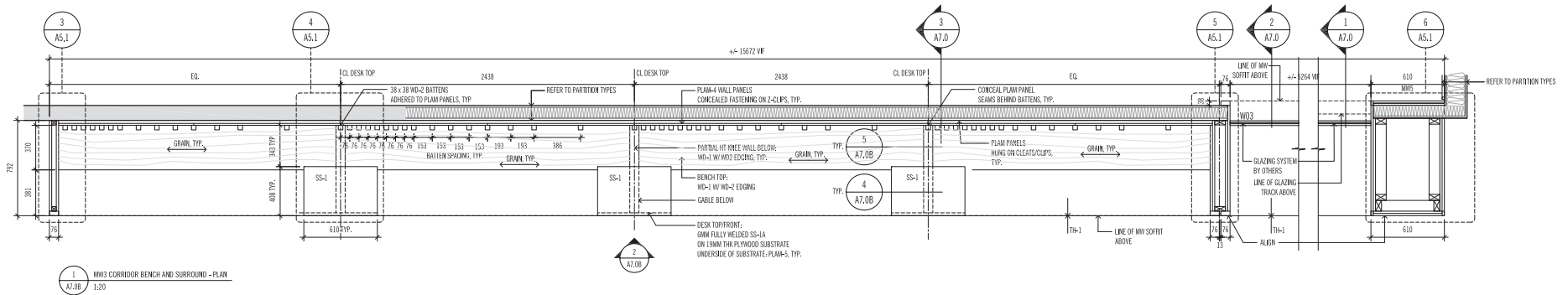

CONSTRUCTION DRAWINGS- CORRIDOR BENCH/SURROUND MILLWORK PLAN & ELEVATION (AUTOCAD)

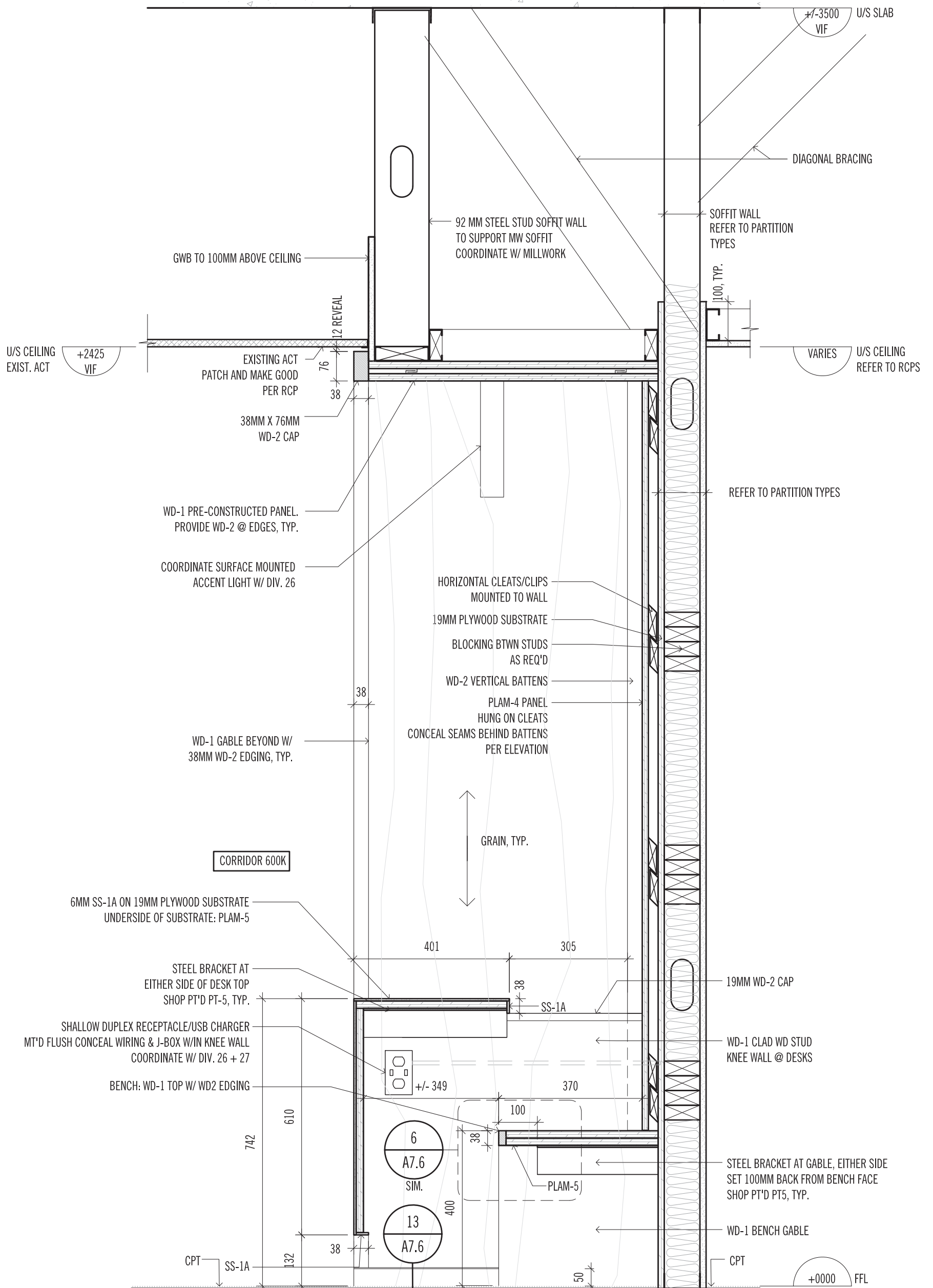

3 MW3 SECTION THROUGH TABLE/BENCH
A7.0 1:10

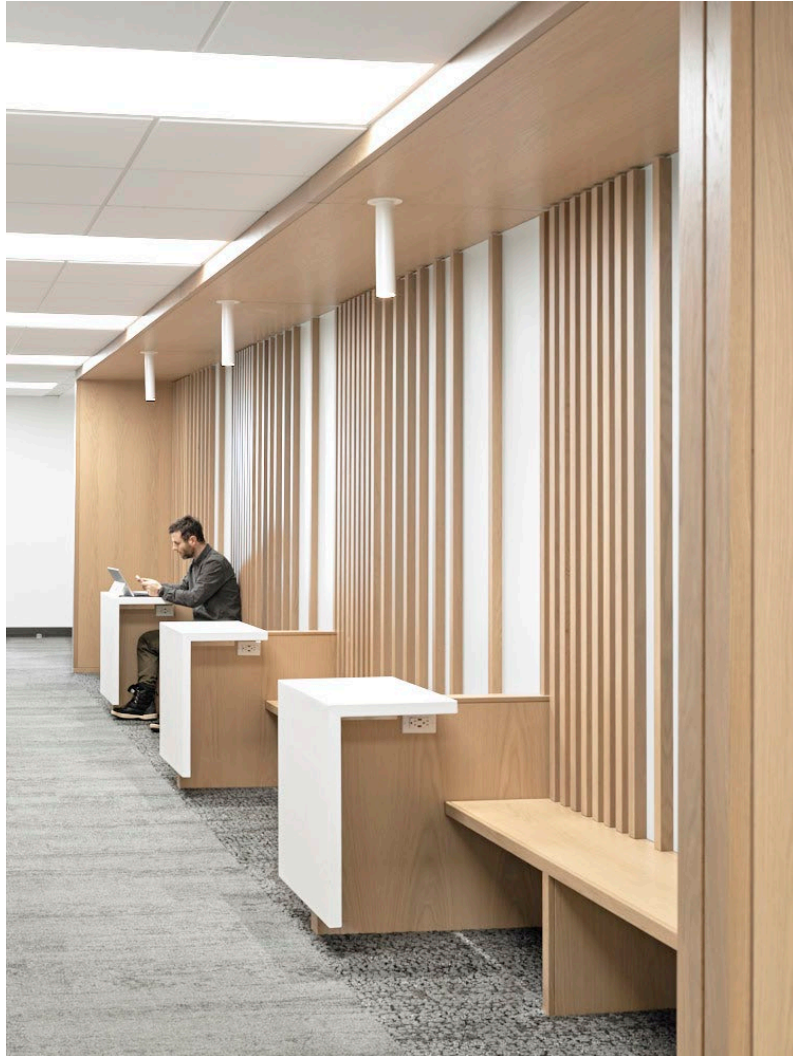

FINISHED PHOTO - CORRIDOR BENCH/SURROUND



FINISHED PHOTO - RECEPTION WAITING AREA



FINISHED PHOTO - RECEPTION MILLWORK

CABBAGETOWN ADDITION | ERA ARCHITECTS



SITE PHOTO OF REAR ADDITION, TAKEN FEBRUARY 2022

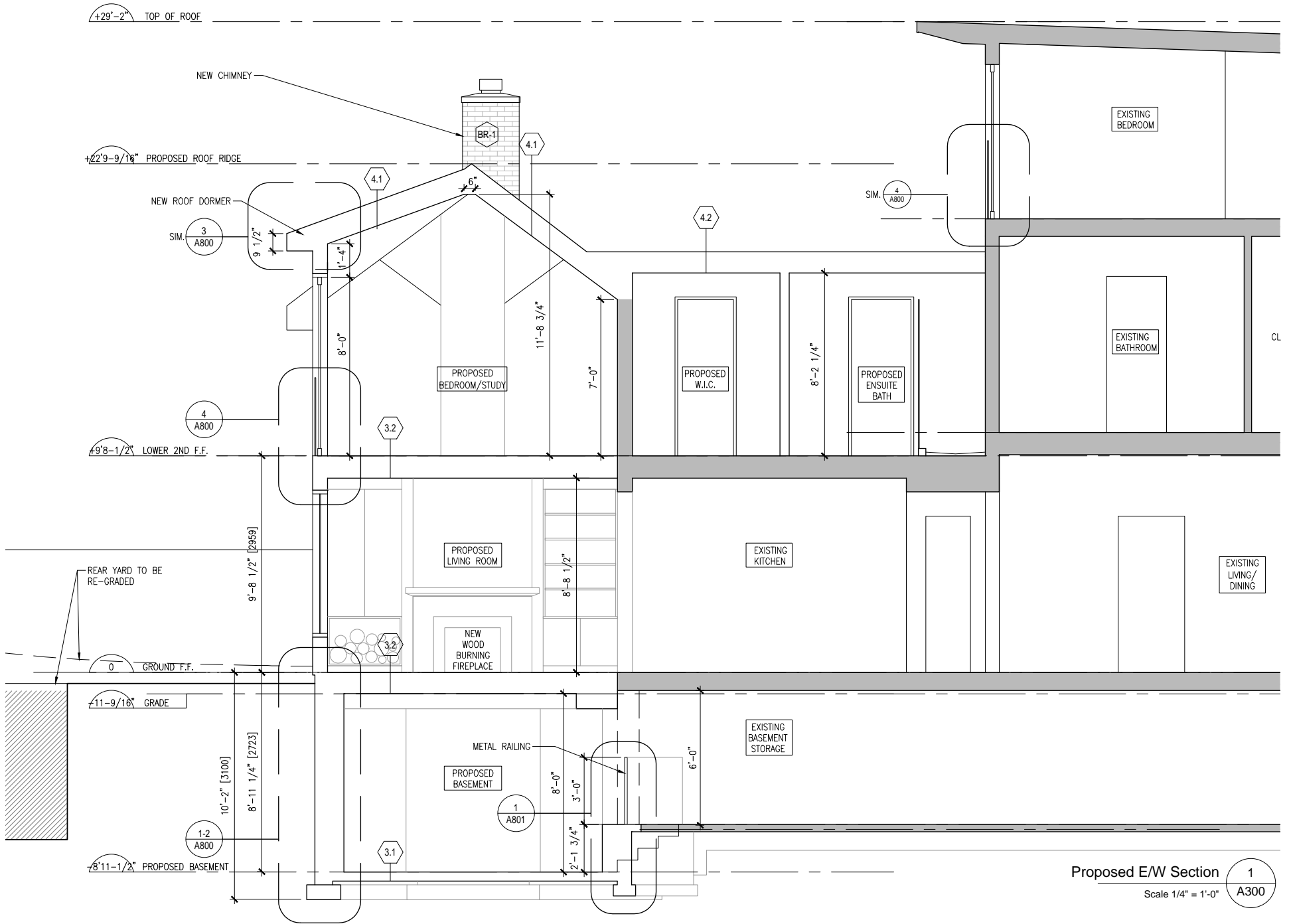

Proposed E/W Section 1
 Scale 1/4" = 1'-0" A300

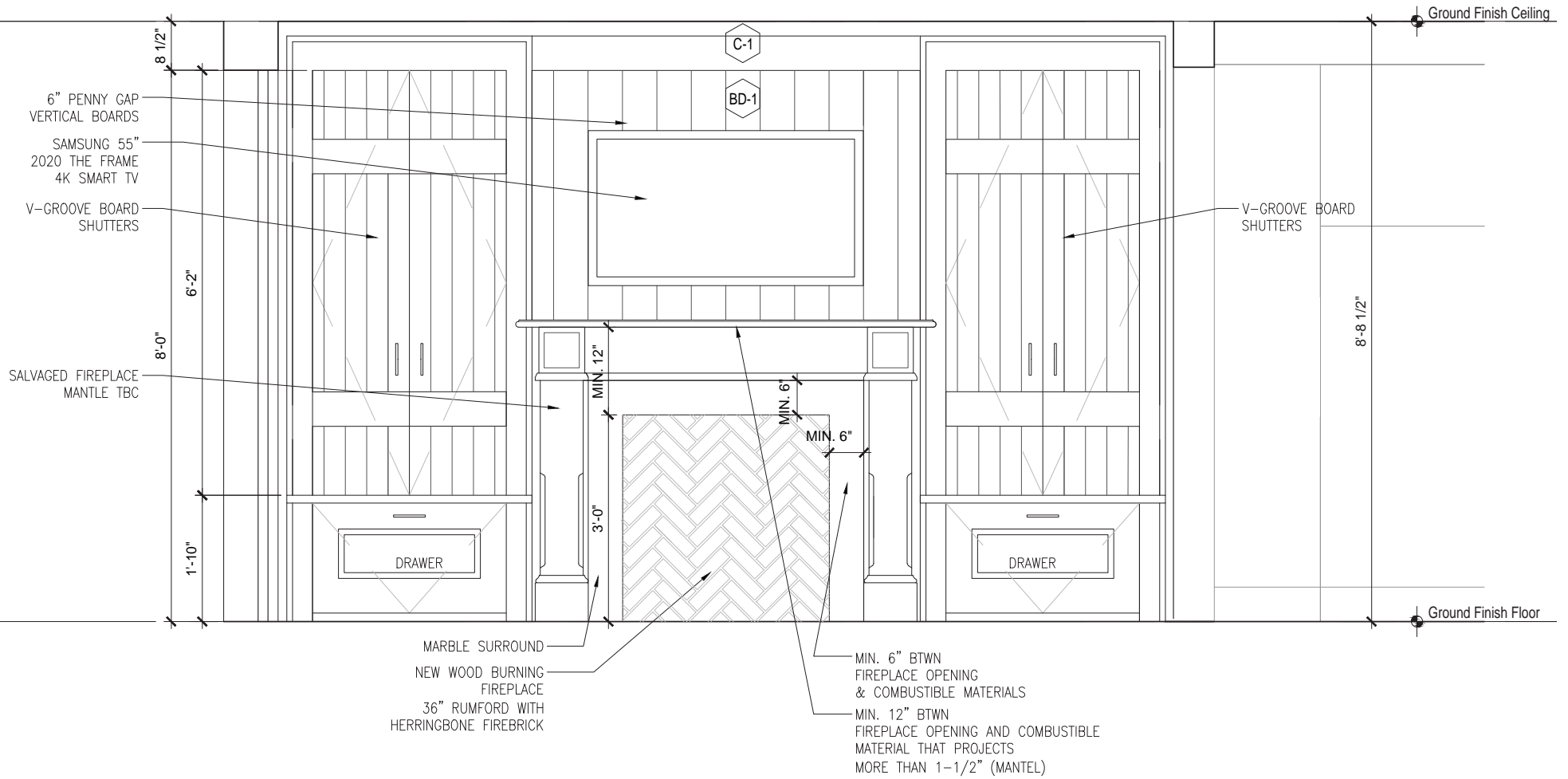

CONSTRUCTION DRAWINGS- LIVING ROOM INTERIOR ELEVATION (AUTOCAD)

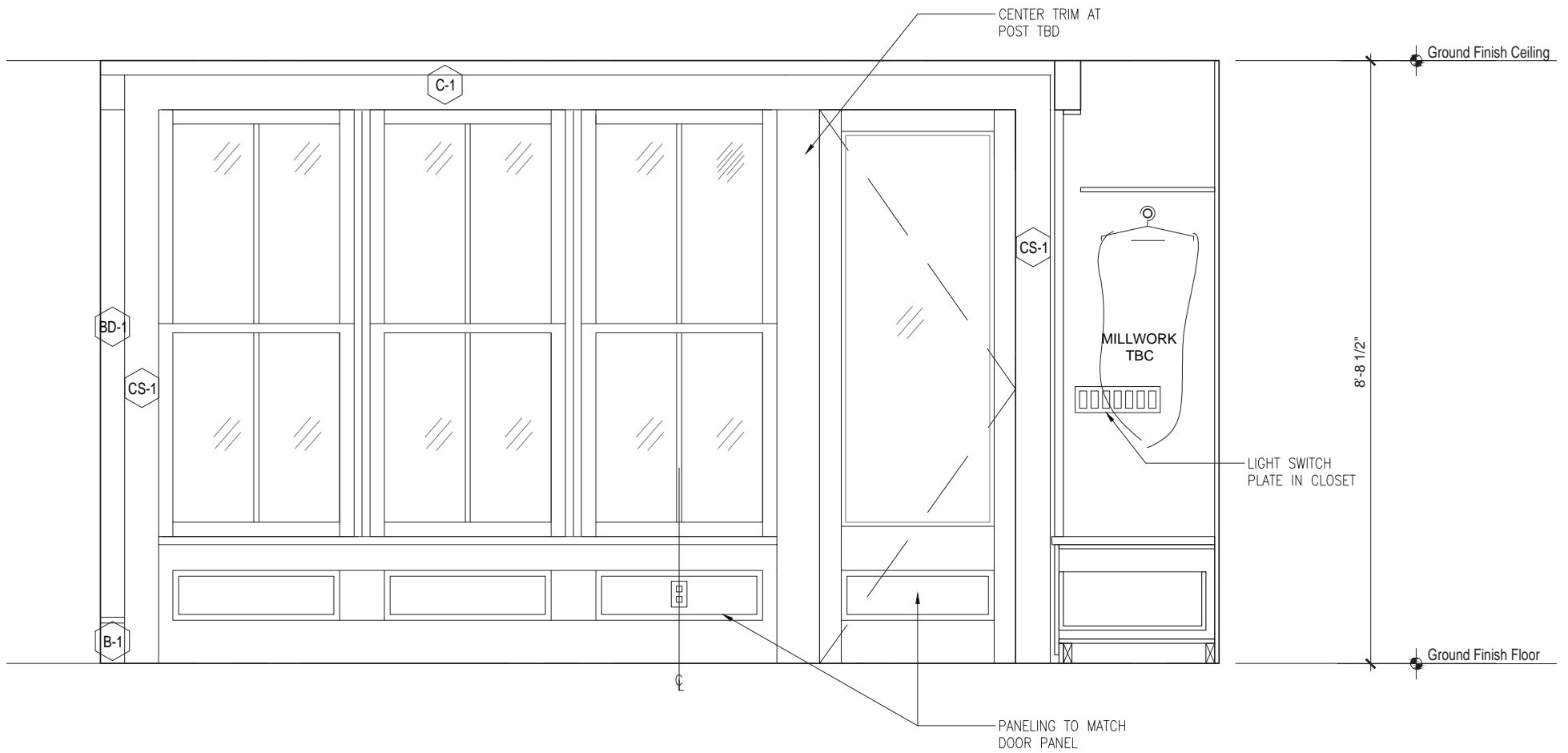

CONSTRUCTION DRAWINGS - LIVING ROOM INTERIOR ELEVATION (AUTOCAD)

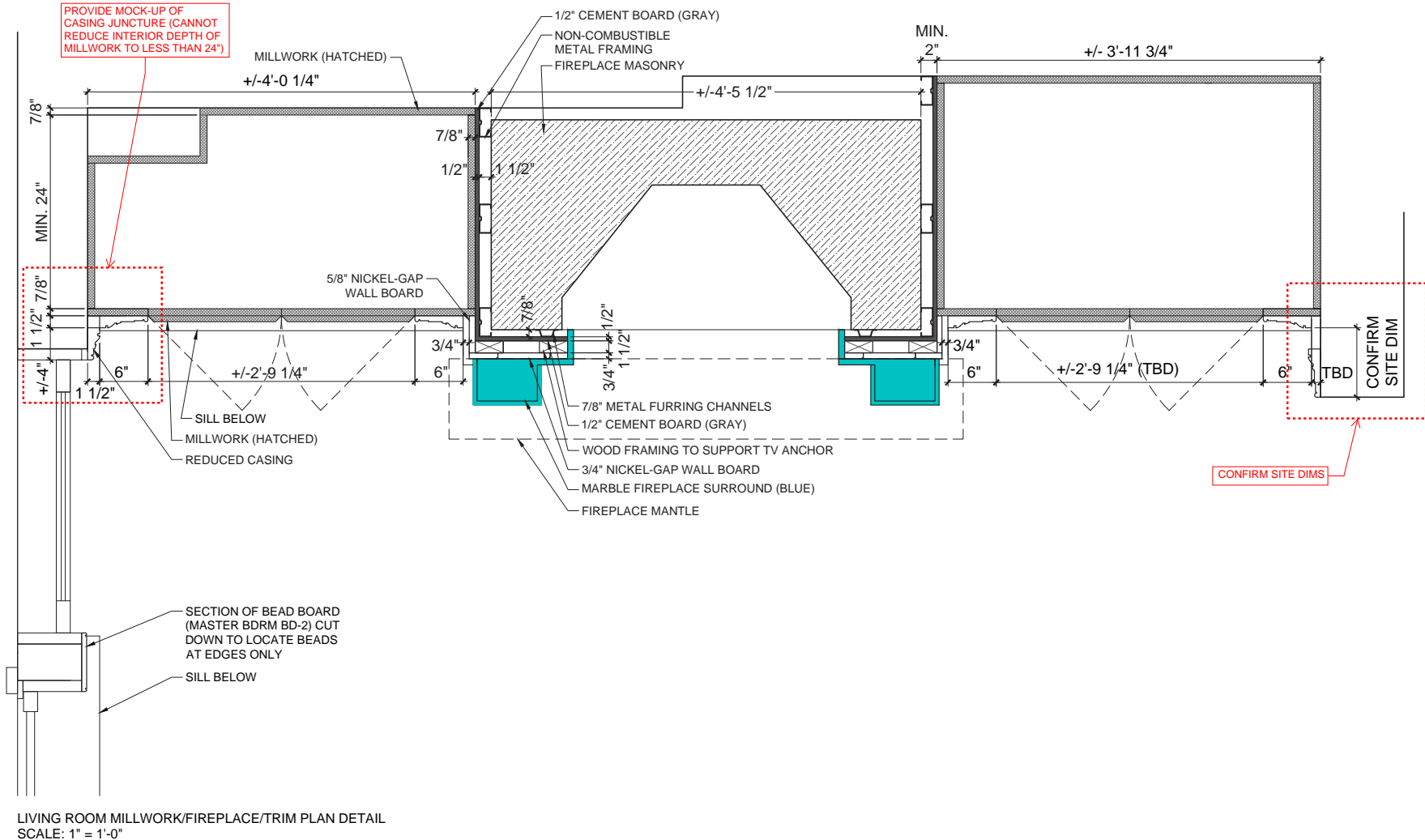

CONTRACT ADMIN - SITE INSTRUCTION EXCERPT- TRIM DETAILS

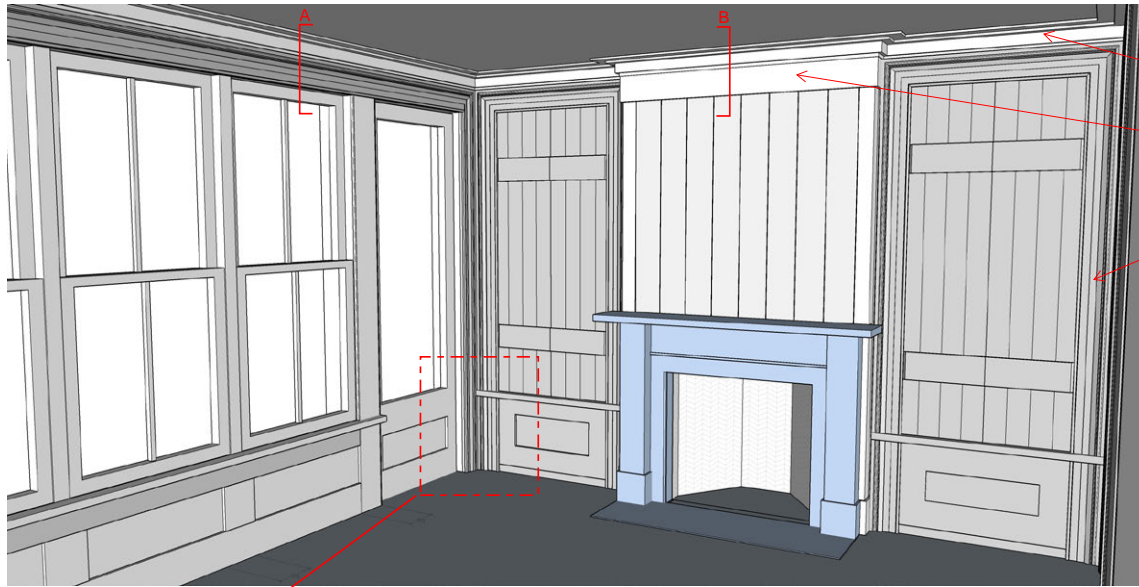

LIVING ROOM - VIEW LOOKING NORTH-WEST

REDUCED CASING TO ACCOMMODATE MILLWORK

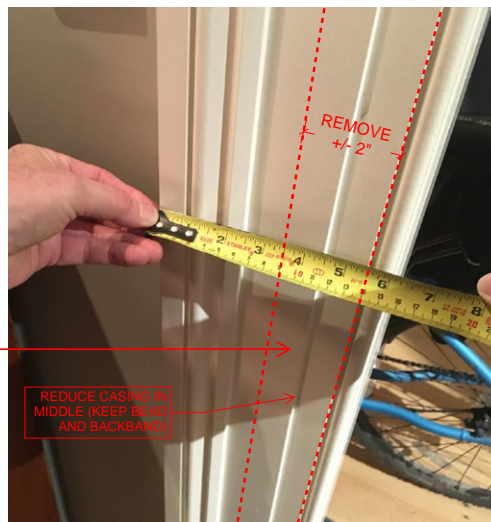
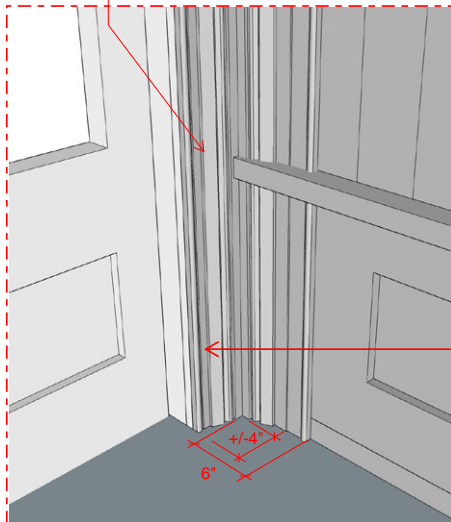

EXISTING CASING

REDUCE CASING IN MIDDLE (KEEP BEAD AND BACKBAND)

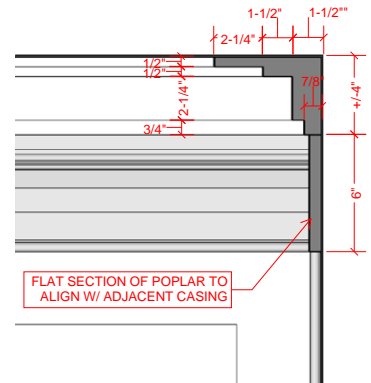

FLAT SECTION OF POPLAR TO ALIGN W/ ADJACENT CASING

A. CROWN MOULDING AT WALL

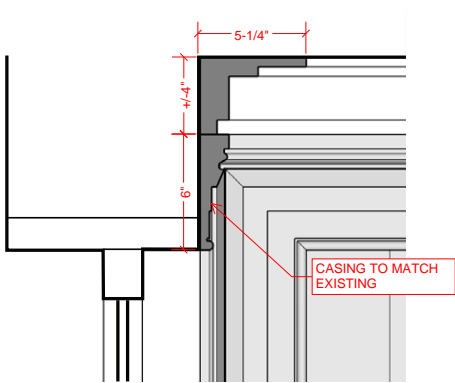

CASING TO MATCH EXISTING

B. CROWN MOULDING AT WINDOW/DOOR

CONTRACT ADMIN - SITE INSTRUCTION EXCERPT- TRIM DETAILS

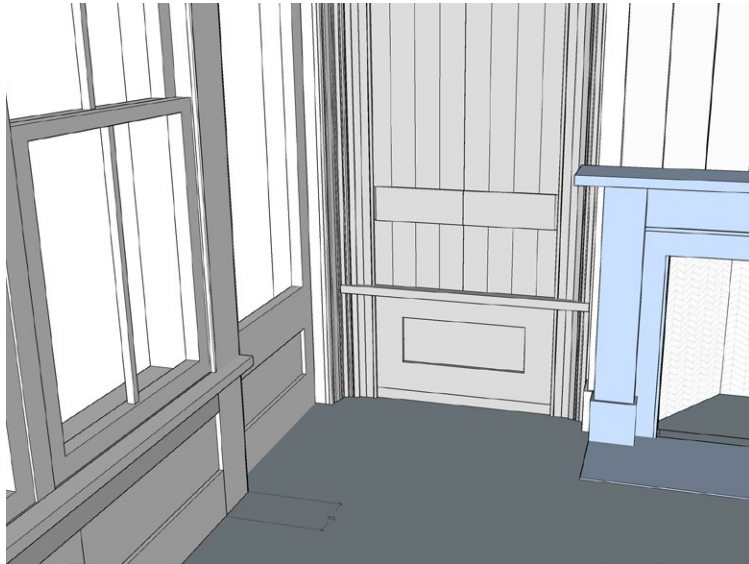

LIVING ROOM - VIEW LOOKING NORTH

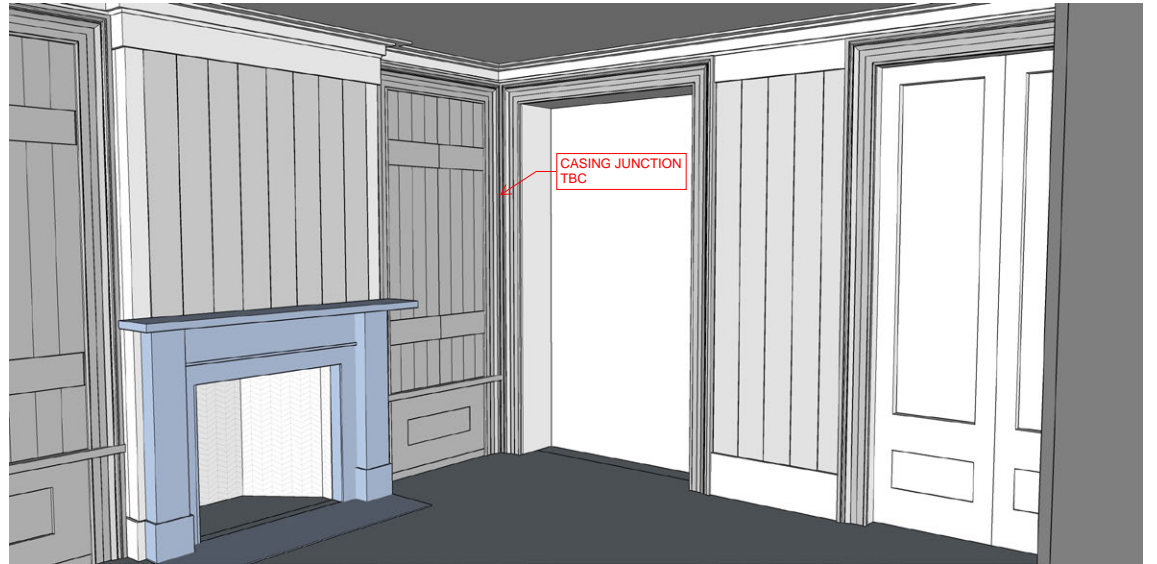

CASING JUNCTION
TBC

LIVING ROOM - VIEW LOOKING NORTH-EAST

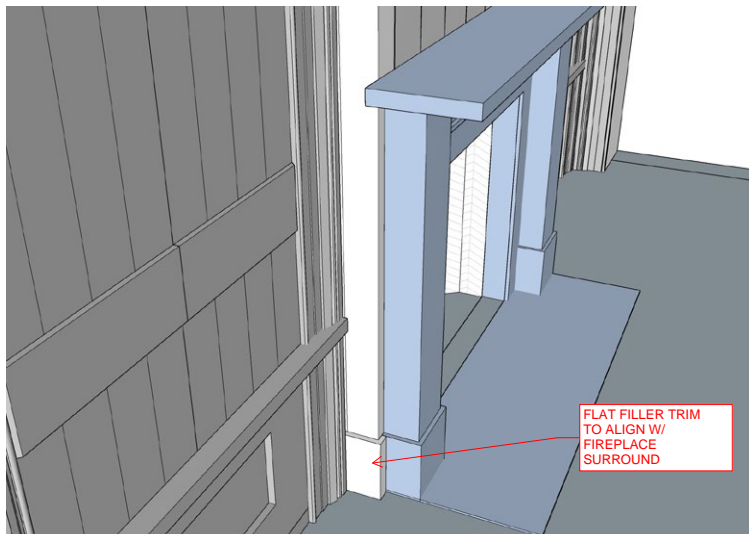

FLAT FILLER TRIM
TO ALIGN W/
FIREPLACE
SURROUND

LIVING ROOM - VIEW OF SIDE OF FIREPLACE SURROUND

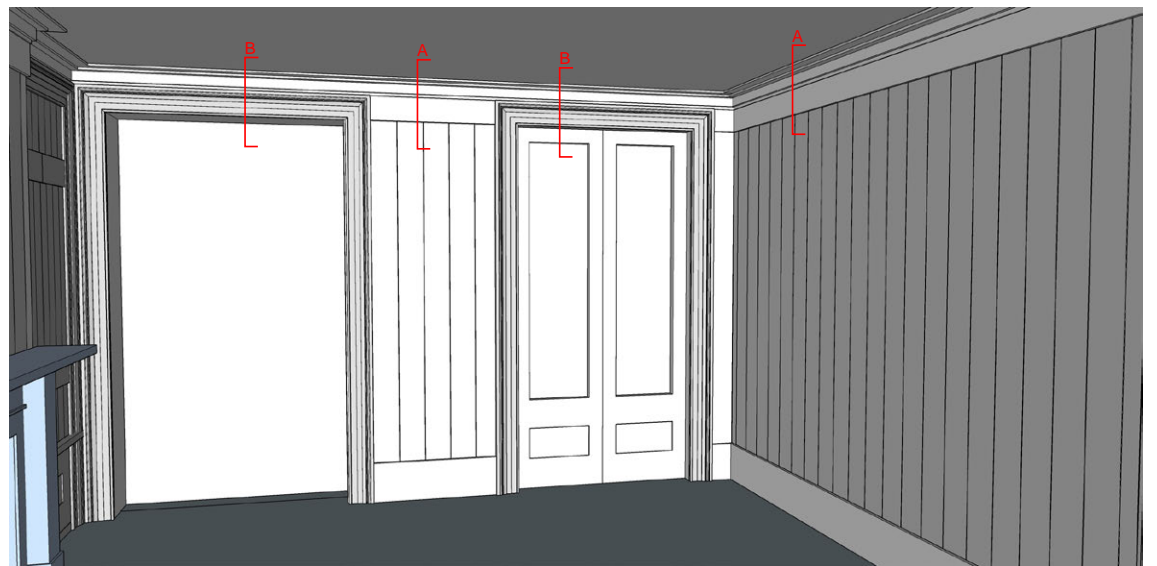

LIVING ROOM - VIEW LOOKING SOUTH-EAST

CONTRACT ADMIN - SITE INSTRUCTION EXCERPT- TRIM DETAILS



LIVING ROOM INTERIORS- PROGRESS PHOTOS

POOL HOUSE | +tongtong / 3RD UNCLE DESIGN



FINISHED PHOTO - POOL HOUSE EXTERIOR



VIEW OF POOLHOUSE EXTERIOR (SKETCHUP)

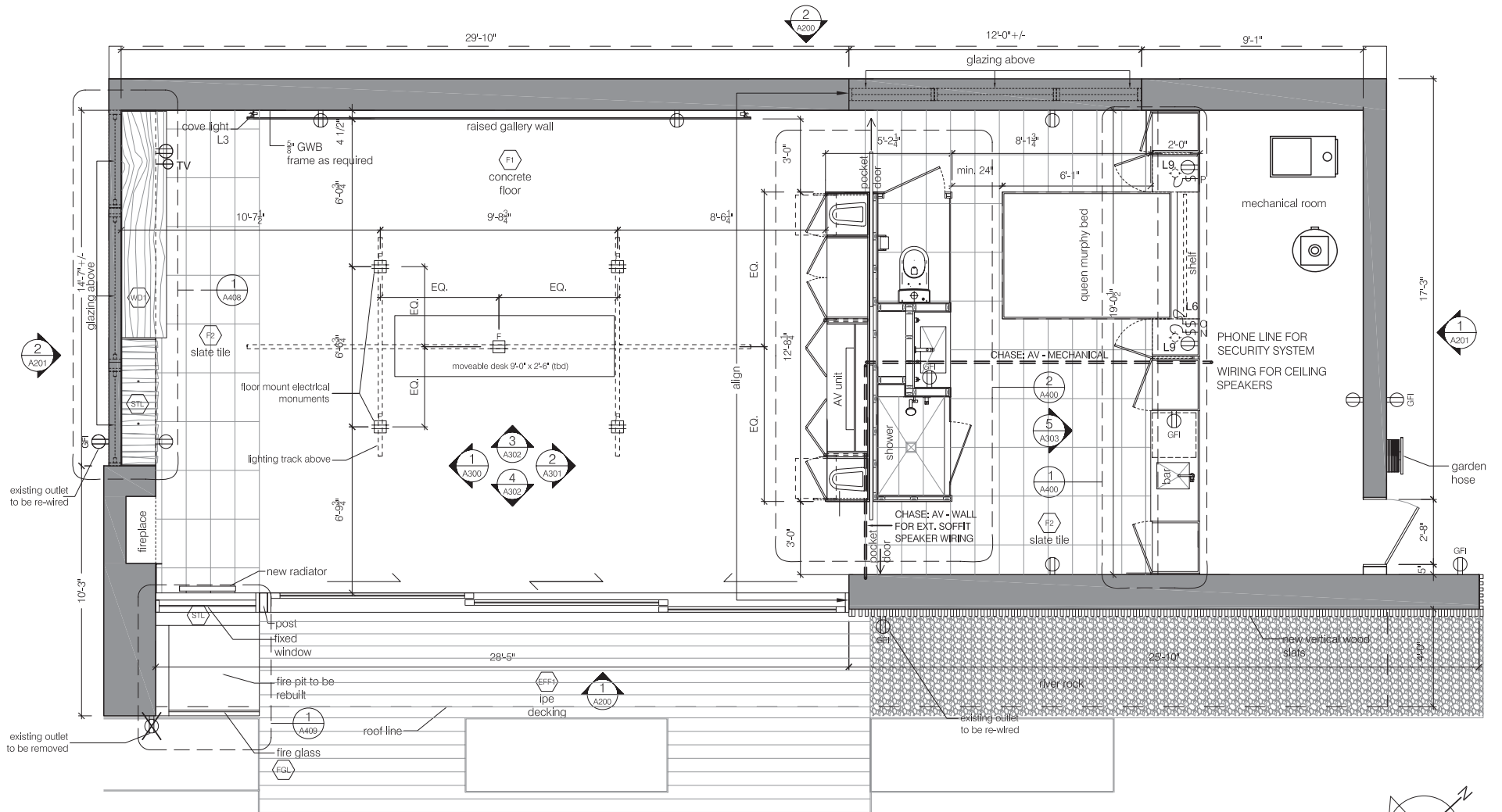

CONSTRUCTION DRAWINGS - PLAN (AUTOCAD)

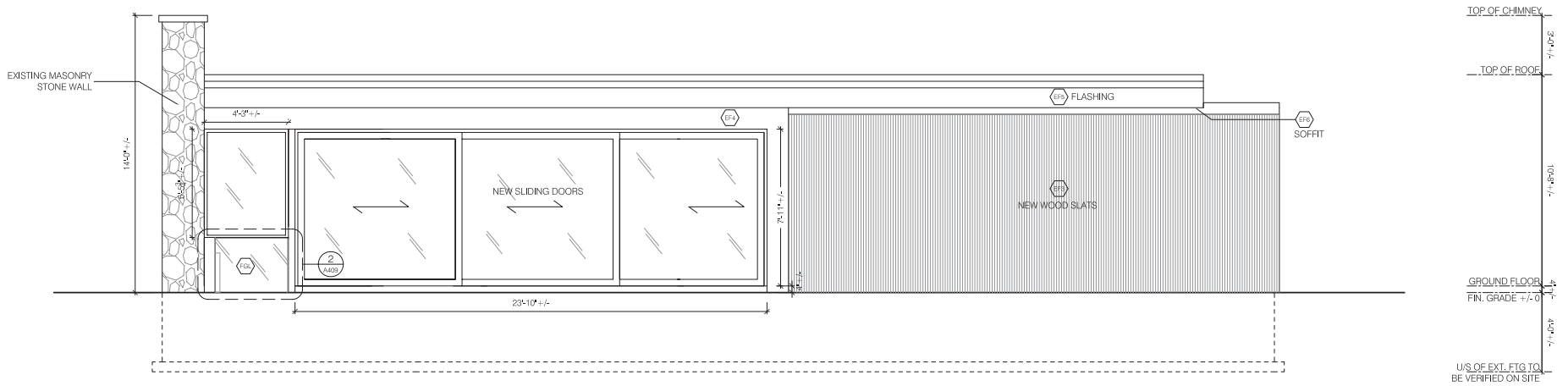

1 Front Elevation
SCALE: 3/16" = 1'-0"

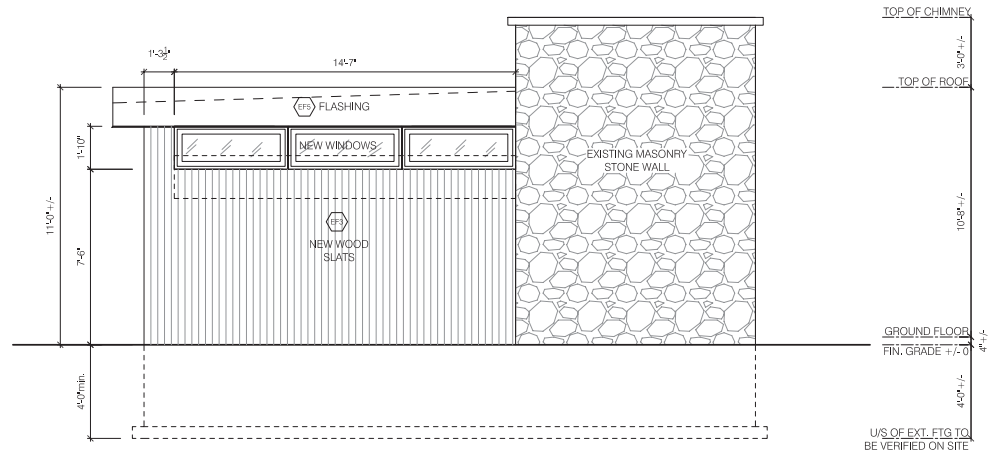

2 Side Elevation
SCALE: 3/16" = 1'-0"

CONSTRUCTION DRAWINGS- EXTERIOR ELEVATIONS (AUTOCAD)

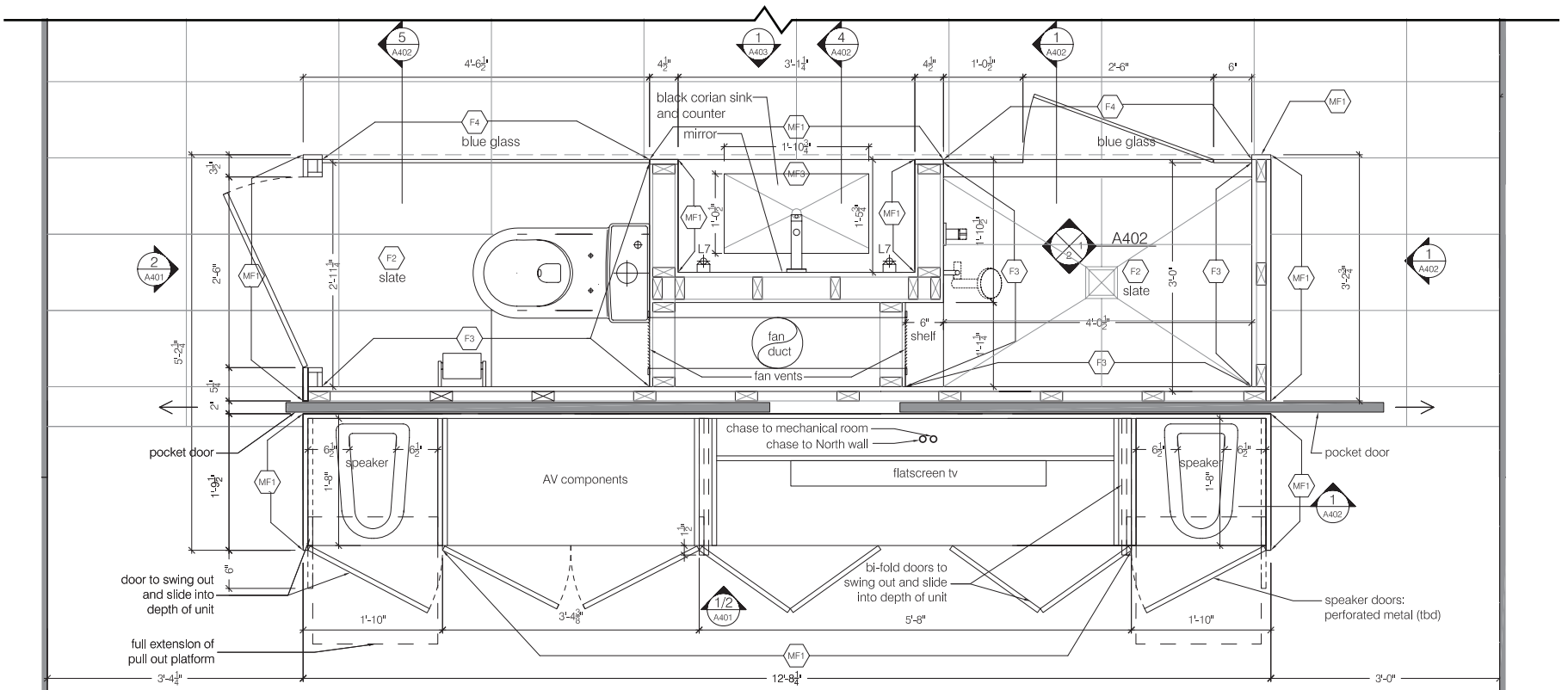
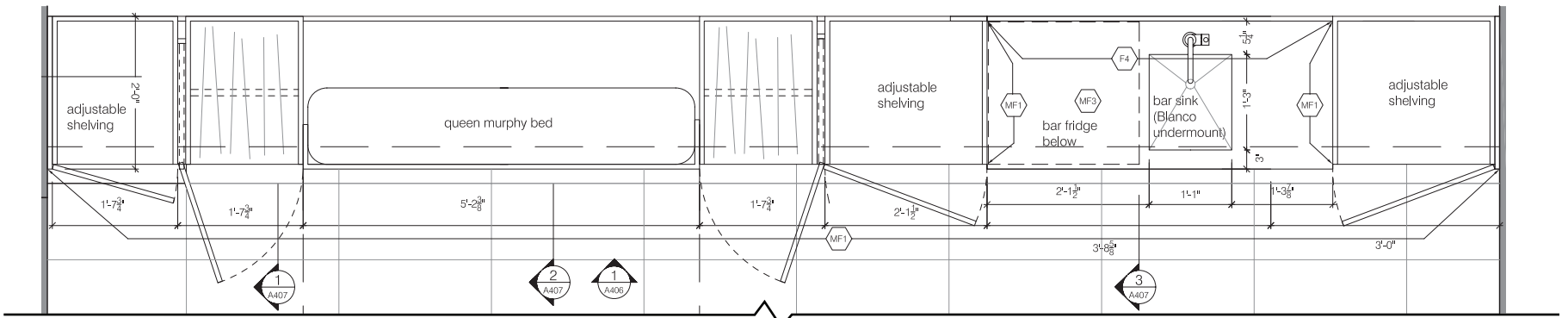

CONSTRUCTION DRAWINGS - MILLWORK PLAN (AUTOCAD)

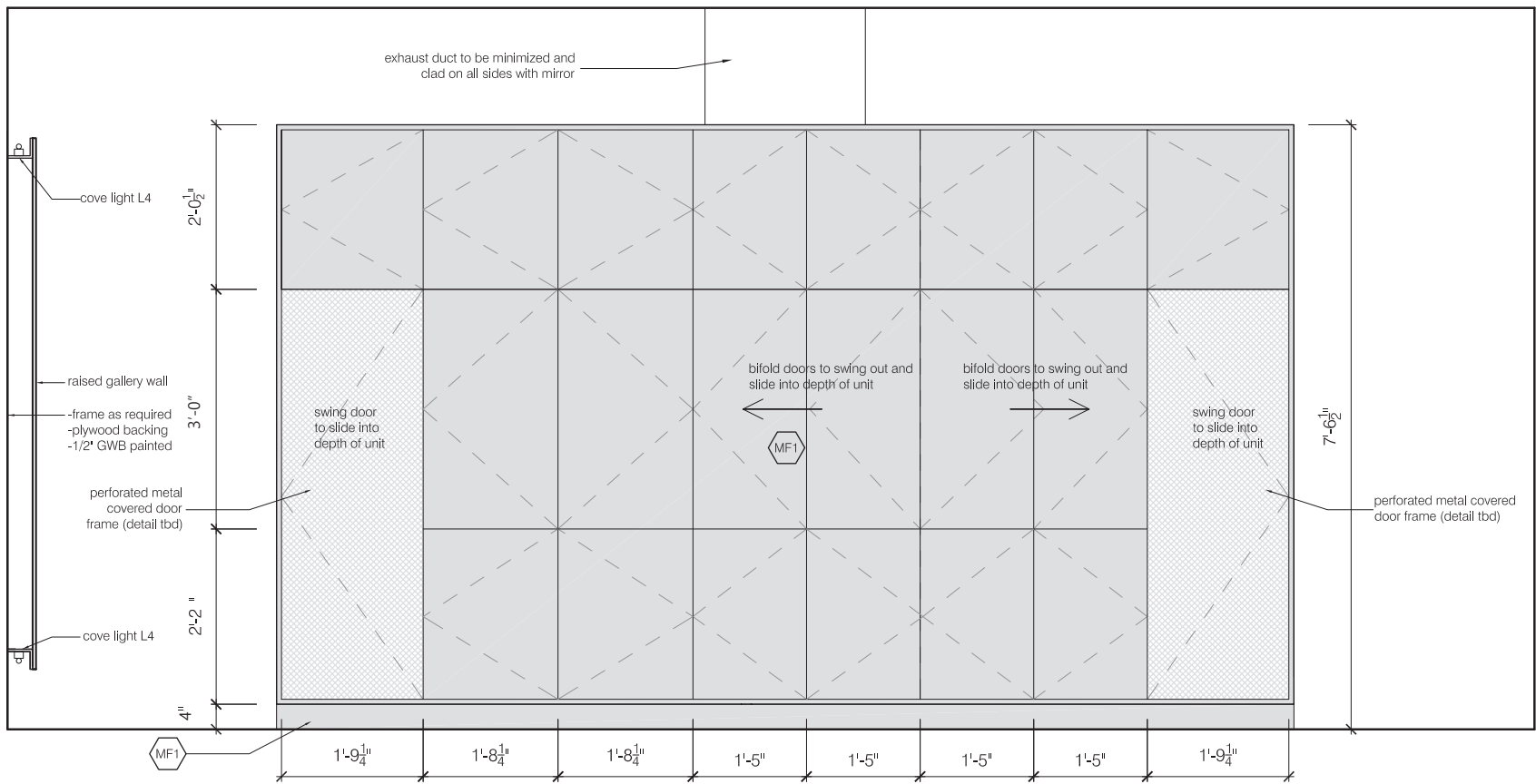

CONSTRUCTION DRAWINGS- CENTRE MILLWORK LOUNGE-SIDE ELEVATION (AUTOCAD)

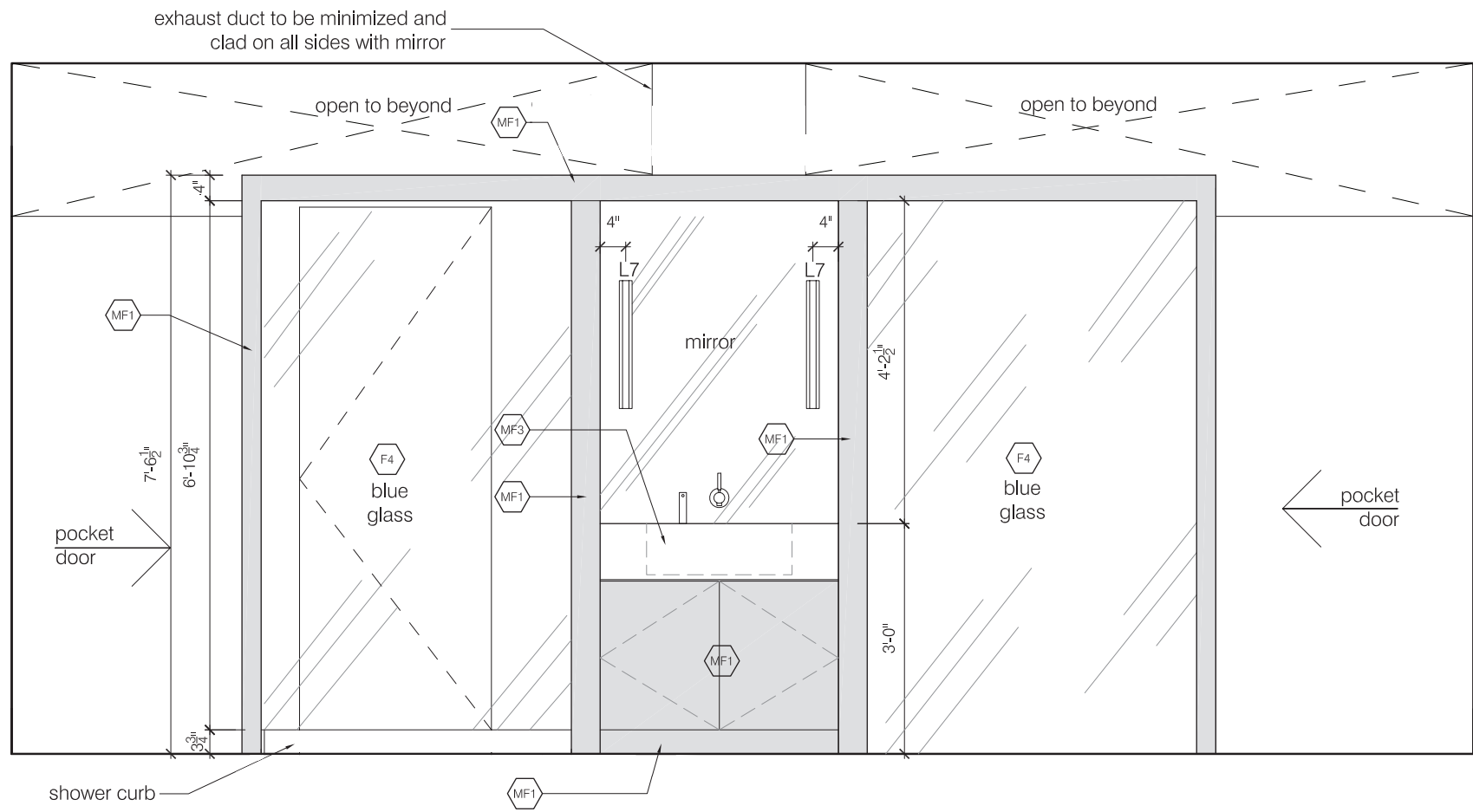

CONSTRUCTION DRAWINGS - CENTRE MILLWORK WASHROOM-SIDE ELEVATION (AUTOCAD)



FINISHED PHOTO - CENTRE MILLWORK



FINISHED PHOTO - WASHROOM



FINISHED PHOTO - LOUNGE SPACE



FINISHED PHOTO - POOLHOUSE EXTERIOR IN EVENING